

ComNav[®]



Voyager X3 Class A AIS Transceiver Automatic Identification System

**Safety & Security
for Deep Sea and
Inland Waterways**

- Compact single box design
- Approval: FCC and USCG standard in USA, Wheel Mark/MED, IEC certified in Canada
- Advanced technological design for enhanced performance & reliability
- Display graphically AIS data target overlay on standard radars and multifunction chart displays
- Wireless exchange — Navigation status between vessels and shore traffic monitoring centers
- Monitor vessels of Class A and Class B over standard VHF data transmissions
- Port traffic management — using Class A and Class B data to identify and control vessel movements
- Transmit safety related messages reducing search and rescue times
- Rotary encoder for quick selection and data entry using two soft keys
- Easily upgradeable through PC software via RS232 — 9 way D type connector
- Built in 16 Channel GPS receiver with antenna
- High contrast monochrome LCD for clear presentation of data
- Dual mode Class A/Inland AIS configurable via built-in menu
- International certification to IEC61993-2 and inland waterways standards
- Fully compatible with ComNav Vector G2/G2B GPS Compasses
- 1 Year warranty
- Worldwide service



**IMO COMPLIANT
WHEELMARK CERTIFIED**

VOYAGER X3

SYSTEM CONFIGURATION & OPTIONS

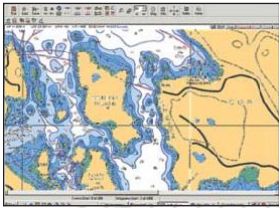

Safety

AIS improves safety on water through enhanced navigation awareness and reduces search and rescue times.



Security

AIS helps to identify and track vessels and improve border security. Improve coast guard response time by transmitting precise navigation data.

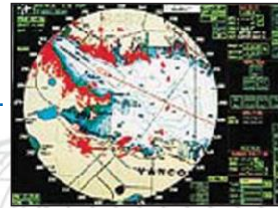

Vessel Monitoring

AIS enables automatic control and intruder or vessel movement alerts within designated areas.

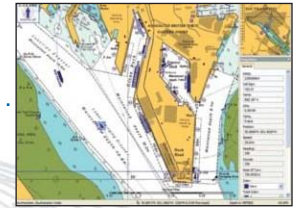

Port Vessel Traffic Management

AIS enables port traffic management by using precise tracking and identification data.

SPECIFICATIONS:

Operating Voltage: 12 to 24 VDC

Power Consumption: 10 watts average, 4.75A peak at 12VDC

NMEA0183 Interface: 38.4k baud bi-directional

RS232 Interface: 38.4k baud bi-directional

Operating Temperature: -15°C to +55°C

CONNECTIONS

VHF Antenna connector: SO-239 (UHF)

GPS Antenna connector: TNC

RS232 Data connector: 9 way D type

IEC61162 interfaces & alarm relay:

Via 50 way D-type junction box.

Power connector: LTWBB-04PMMS-LC7001

VHF TRANSCEIVER

Transmitter: Single

Receivers: Three (two AIS and one DSC channel 70)

Frequency Range: 156.025MHz – 162.025MHz

Channel Bandwidth: 25KHz

Power Output: 41dBm +/- 1.5dB

Modulation: 25KHz GMSK / 25KHz AFSK

Data Rate: 9600 bps GMSK & 1200 bps FSK

RX Sensitivity: <-107dBm @ 20% PER

Compliance: FCC, USCG, Type EU, IEC, CE, RoHs

Standards and Approvals:

- CCNR/ZKR Inland AIS Requirements
- IEC60945 Edn. 4.0 Environmental requirements
- IEC61993-2 Class A Shipborne equipment
- IECIEC61162-1/2 Edn.2.0 Digital interfaces
- EC61108-1 GPS Receiver equipment
- ITU-RM.1371-3 Universal AIS Technical Characteristics



DIMENSIONS: 210mm x 105mm x 138mm / 8.3" x 4.2" x 5.4" W x H x D

WEIGHT: 1.6kg

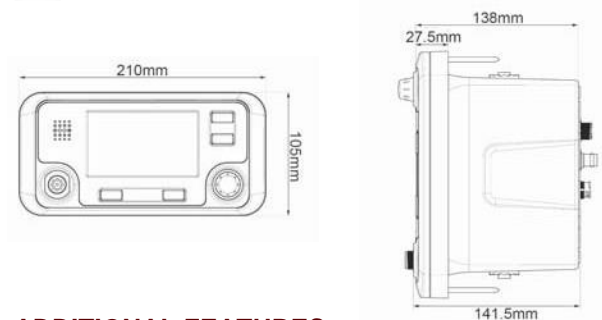

ADDITIONAL FEATURES:

- Configuration and set up software
- Data display for MMSI, vessel name, call sign, vessel type, etc.
- Auto configuration for safety related message
- GPS display of position, COG and SOG
- GPS diagnostics
- Key status indicators
- Shows Transponder software and firmware version
- Displays receiver and transmitter statistics
- Displays Class A, Class B, base station and A to N target data
- Real time display for serial data output
- Ability to log data to file

ComNav®



ComNav Marine Ltd.

#15-13511 Crestwood Place,
Richmond, British Columbia • Canada • V6V 2G1

Phone: 604-207-1600 • Fax: 604-207-8008

E-mail: sales@comnav.com

www.comnav.com

Worldwide Service

Printed in Canada

Represented by:



Specifications subject to change without notice

Rev: May2015