

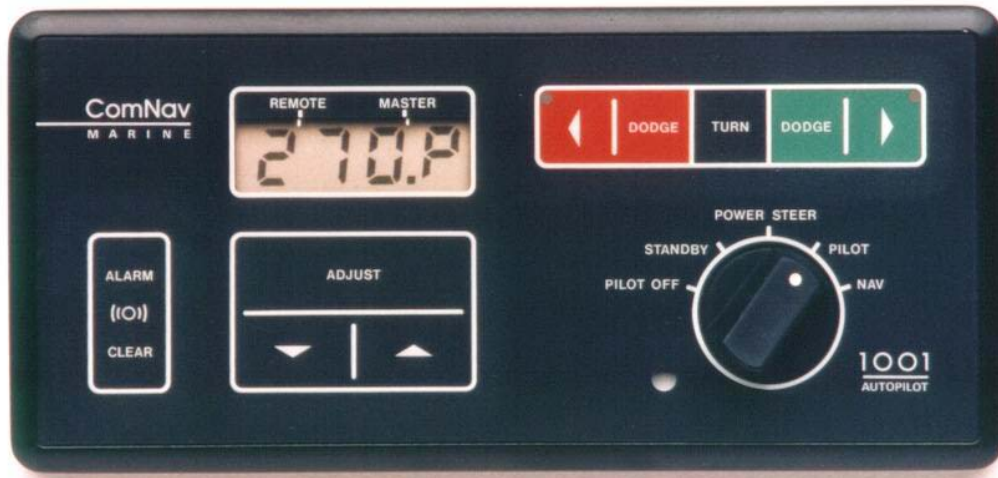

Installation & Operation Manual

ComNav 1001 Autopilot



COMPLIES WITH
CE REGULATIONS

P/N 29010007

WARRANTY NOTICE

Prior to the installation and/or operation of the Equipment, ensure that you read, understand and accept the conditions of the warranties as detailed on the following pages.

OPERATORS WARNING

This Autopilot will automatically steer your vessel however, it is only an aid to navigation. Its performance can be affected by many factors including equipment failure, environmental conditions and improper handling or use. This system does not reduce your responsibility for the control of the vessel when underway. You must always be in a position to monitor the course, supervise the Autopilot, and resume manual control if the need to do so arises.

Whenever underway, your vessel must be under the control of a qualified and alert person.

TABLE OF CONTENTS

1001 AUTOPILOT SYSTEM DRAWING	3
BASIC OPERATION	3
AUTOPILOT	4
REMOTE CONTROL	6
INTRODUCTION	7
SPECIFICATIONS	8
1001 AUTOPILOT INTERCONNECTION DIAGRAM	9
OPTIONAL DRIVE SYSTEMS	11
INSTALLATION INSTRUCTIONS	12
AUTOPILOT	12
COMPASS	13
DISTRIBUTION BOX	18
RUDDER FOLLOWER	21
NAVIGATION INTERFACE	24
CROSS TRACK ERROR RESPONSE	26
CHECKSUM EVALUATION	27
DOCKSIDE SET-UP	28
SETTING OF RUDDER TRAVEL LIMITS	28
ADJUST RUDDER ANGLE INDICATOR (if installed)	29
CONFIGURING THE COMPASS	30
NAVIGATION EQUIPMENT INTERFACING	30
SEA TRIALS	31
CONTROLS	36
MASTER SELECT SWITCH	36
MEMBRANE KEYPAD	37
SPECIAL TURNS	40
EMERGENCY TURN	40
CONTINUOUS TURN	40
U TURN	41
OPERATION	42
STANDBY	42
POWER STEER	43

PILOT	44
NAV	47
REMOTE CONTROLS	48
<i>REMOTE CONTROLS</i>	<i>50</i>
COMNAV 101 REMOTE CONTROL	50
COMNAV 201 REMOTE CONTROL	53
COMNAV 211 REMOTE CONTROL	54
<i>ERROR CHECKING</i>	<i>55</i>
PROBLEM SOLVING	59
<i>CE COMPLIANCE</i>	<i>62</i>

1001 AUTOPILOT SYSTEM DRAWING

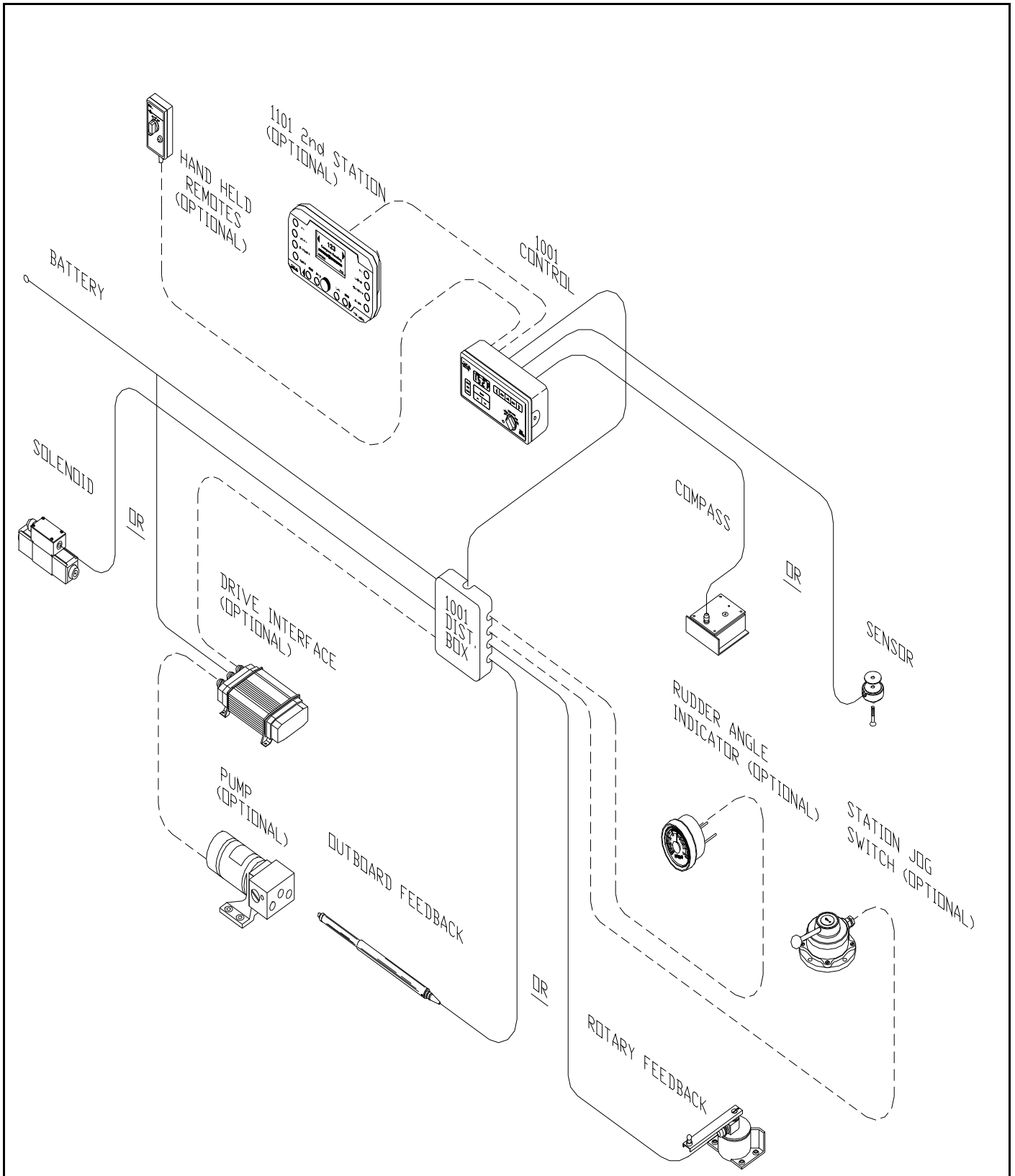

BASIC OPERATION

AUTOPILOT

1. TO INITIALIZE THE AUTOPILOT STANDBY MODE

- Turn the master select switch to the **STANDBY** position. The display will show the vessel's current compass heading. If the heading displayed by the autopilot does not agree with the compass, press the **ADJUST** key twice to display the current heading offset, and then use the up or down **ARROW** key to adjust the offset by the amount of the error.

- To turn on the speed sensitivity that switches between FAST and SLOW when in PILOT or NAV, with the Pilot in Standby press the **ADJUST** key until 'SP: 0' is displayed. Press the up **ARROW** key until the desired speed is displayed.

- To turn off the speed sensitivity, press the down **ARROW** key until the display reads 'SP: 0'.

- If the display is too bright or too dim when viewed in full darkness, press the **ADJUST** key until 'Lt' is displayed, and then use the up or down **ARROW** key to adjust the minimum brightness level between 0-9.

- To select a Special Turn as described in (4) below, press the **TURN** key followed by either the red or green **ARROW** key.

- To initiate a Full Reset, press and hold both the up and down **ARROW** keys for one second. This will reset all autopilot parameters back to factory settings and the Pilot will go into Reset mode. *A dockside set-up will be required after every Full Reset.*

2. TO POWER STEER THE VESSEL POWER STEER MODE

- To turn the rudder to port and to starboard, turn the master select switch to the **POWER STEER** position. While either the red or green **ARROW** key is pressed, the display will show the vessel's rudder angle and will show the vessel's current compass heading at all other times.

- To display the vessel's rudder angle, press the **TURN** key once. To return compass information to the display, press the **TURN** key again.

- To zero the digital rudder angle display, turn the rudder to dead ahead, press the **ADJUST** key until the flashing rudder angle display appears and press the up or down **ARROW** key until the rudder angle display shows ' :00'.

3. TO BEGIN AUTOPILOT CONTROL OF THE VESSEL:

- To have the vessel continue on its present heading under autopilot control, turn the master select switch to the **PILOT** position.

- To select either the 'FAST' (High Speed) mode or the 'Slow' (Low Speed) mode, press the **ADJUST** key once followed by the up or down **ARROW** key. *This will be done automatically if the speed sensitive switching has been turned on in (1) above.*

- To adjust the rudder gain setting for the High or Low speed mode, press the **ADJUST** key until 'rud' is displayed, followed by the up or down **ARROW** keys. Similarly adjust the counter rudder ('ctr') and yaw ('YAW') settings for best steering.

4. TO CHANGE THE VESSEL'S COURSE:

- To obtain the desired course, leave the master select switch in the **PILOT** position. Estimate the number of degrees of course change required.

- Until the display shows the desired course, alter the course in one degree steps by pressing and releasing either the red or green **ARROW** key.

--- Or ---

Alter course by ten degrees per second by pressing and holding either the red or green **ARROW** key.

- To select a special turn (U-turn, Emergency Turn, or Continuous Turn), with the Pilot in Standby mode, press the Turn key once followed by the Green key until the desired Turn is displayed.

- To adjust the rate at which the vessel will turn to the new course, press the **ADJUST** key until 'trn' is displayed and then press the up or down **ARROW** key

5. TO DODGE THE VESSEL OFF COURSE\PILOT MODE

- To avoid obstacles in the water, press either the red or green **DODGE** key for a panic turn in the desired direction.

- To keep the vessel off course, after it has turned far enough to clear the obstacle, press and hold both **DODGE** keys.

- To return to the programmed course at the rate set by the turn rate control. Release the **DODGE** key

6. TO INTERFACE WITH A NAVIGATION COMPUTER\NAV MODE

- Start navigating towards a selected route or waypoint, using a Navigation Computer which has an NMEA 0183 output.

- Turn the autopilot master select switch to the **NAV** position. The autopilot will set its own course using information sent to it by the Navigation Computer.

- To select the response to cross track error (normal or reversed), press the **TURN** key and then the green **ARROW** key.

- The **DODGE** keys operate as described in (5) above, except that the vessel will return to the original track to the waypoint, rather than the original course, when the **DODGE** keys are released.

For more complete operating instructions, refer to the **CONTROLS** and **OPERATION** sections.

REMOTE CONTROL

The autopilot master control unit must be on to use any remote control. The vessel's compass heading is shown at all times on the display of the unit that is **NOT** in control. As a further reminder, the function indicator (see Figure 8) will be flashing on the display of the unit that is **NOT** in control.

1. TO USE THE COMNAV 101 REMOTE CONTROL:

- To take control at the Remote, press both its pushbuttons for one second. The command point on all displays will move to the **REMOTE** position. *This control operates identically to the autopilot, except that there is a toggle switch, used together with one of the pushbuttons, to dodge or to initiate a special turn.*

- To recall the vessels last course, hold the toggle switch in the **DODGE** position while turning the master select switch from **POWER STEER** to **PILOT**. The course that the autopilot was steering when it was last in **PILOT** will be recalled. (If the autopilot has not been in **PILOT** since it was turned on, the course the vessel was on at the moment the autopilot was turned on will be recalled.)

2. TO USE THE COMNAV 1101 SECOND STATION:

- To take control at the Second Station, press both **DODGE** keys for one second. The Command Point on all displays will move to the **REMOTE** position.

- The 1101 second station operates identically to the autopilot, except that the **OFF/FUNCTION** will not operate. The autopilot must be turned **ON** and **OFF** from the autopilot front panel.

3. TO TAKE CONTROL AT THE AUTOPILOT FRONT PANEL:

- To take control at the autopilot front panel, press both the red and green **ARROW** keys on the autopilot front panel for one second. The command point on all displays will move back to the **MASTER** position.

For more complete operating instructions refer to the **REMOTE CONTROLS** section.

WARNING

If the unit that will take control is not in the same mode as the unit currently in control, a sudden course change could occur.

INTRODUCTION

This autopilot is a microprocessor operated PID (Proportional-Integral-Differential) controller, working from either a high quality, externally gimballed magnetic ships steering compass fitted with a fluxgate sensor or a direct earth's field sensing fluxgate compass.

Heading information is compared against the programmed heading, and the desired rudder position determined. The desired rudder position is compared against the actual rudder position transmitted by the rudder follower. If they are not the same, either the Port or Starboard output line is activated.

The Port and Starboard output lines are active low (i.e. switch to ground), and can drive a load of up to 3 amps. They are designed to operate solenoid valves in a hydraulic steering system.

A speed control signal is also available for use with variable speed rudder drives. The outputs, either by themselves or with an optional solid state drive box, can be adapted to operate a wide variety of power steering systems.

If the autopilot is installed as a retrofit, it is usually possible to use the existing power steering installation. The autopilot can operate from either 12 or 24 VDC power systems.

The autopilot has our unique Ghost Rudder feature. In case of a rudder follower failure the autopilot will automatically switch to Ghost Rudder, which calculates the rudder position instead of measuring it, and continue to operate at a reduced performance level.

The autopilot is equipped to interface with a GPS, Loran C, or any other navigation computer which outputs one of the NMEA 0183 formats at 4800 Baud.

The autopilot is designed to accept one remote control.

By adding the optional REMOTE EXPANDER, the autopilot can support any combination of up to four remote controls or second stations.

Figure 1 shows the possible interconnections between the autopilot, it's accessories, and external equipment.

SPECIFICATIONS

Operating Voltage:	10 VDC TO 30 VDC For Use With 12 or 24 VDC Battery Systems only
Operating Current:	0.18 Amps (minimum)
Operating Temperature Range:	-15 To +60 °C
Heading Resolution:	0.25 Degree
Heading Accuracy:	± 2.0 Degrees
Course Set Resolution:	1.0 Degree
PORT/STBD Output Type:	Open Collector, 3 Amps Max
Speed Control Output:	2.50 VDC for No Movement 5.00 VDC for Maximum Speed Port 0.00 VDC for Maximum Speed Starboard 10K ohm Source Impedance
Navigation Input:	NMEA 0183 (4800 BAUD): RMA, RMB, RMC, APB, APA, XTE, BOD, WBD, HSC, VBW, VHW, VTG
Rudder Angle Indicator Output:	± 500 Micro-Amp Full Scale Deflection
Size	
Wide:	8.25 inches (210mm)
High:	3.75 inches (95mm)
Deep:	2.25 inches (57mm) 3.0inches(76mm) required behind unit for cabling
Weight:	4.0 lbs (1.6 kg)

ComNav 1001 Autopilot INTERCONNECTION DIAGRAM

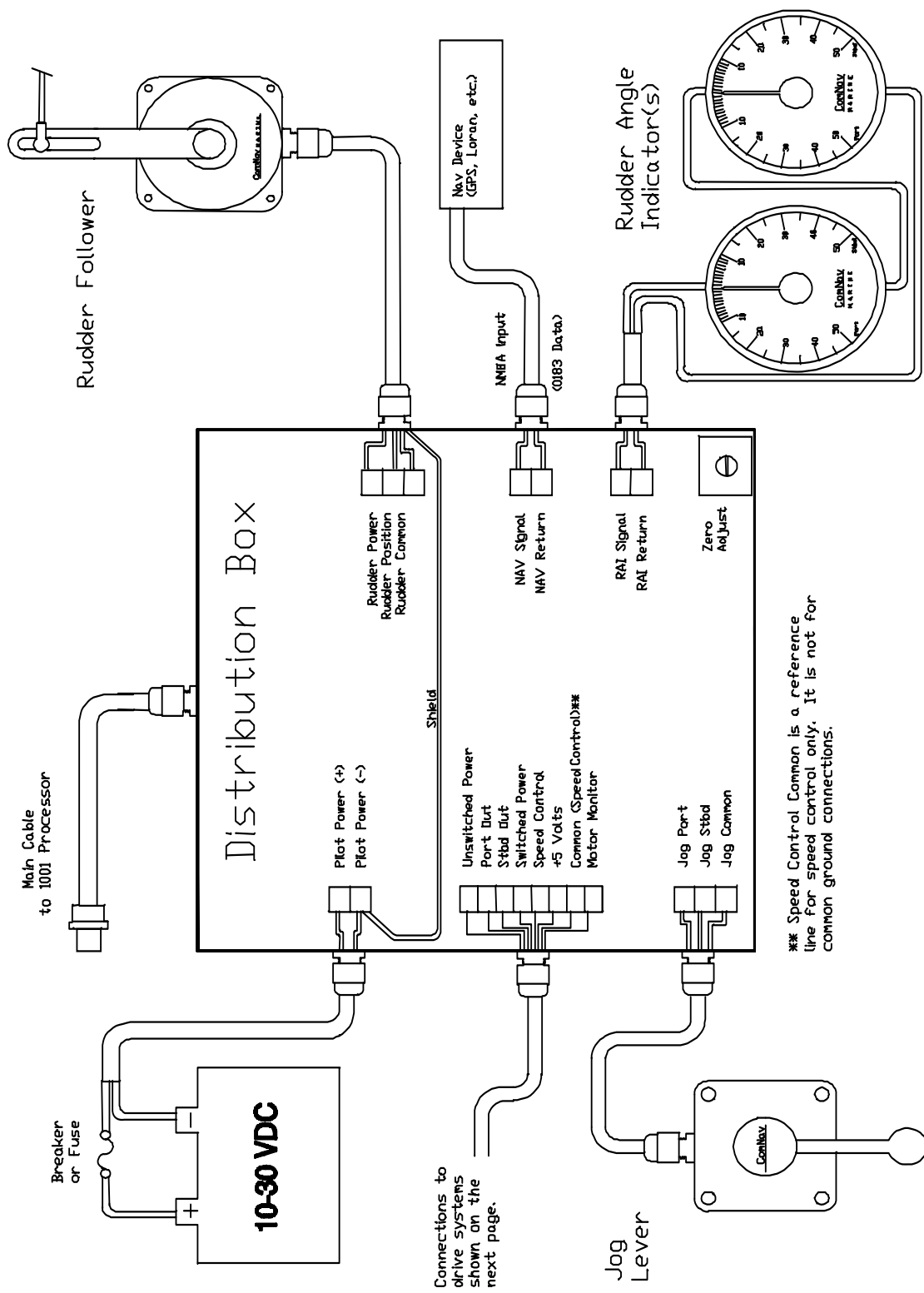

Up to three RAI units may be used. Wire them in series if the Distribution Box has a zero adjust potentiometer, or in parallel if the Distribution Box does not have a zero adjust.

1001 AUTOPILOT INTERCONNECTION DIAGRAM

DRIVE SYSTEM OPTIONS

A) FOR STANDARD FOUR-WAY VALVES

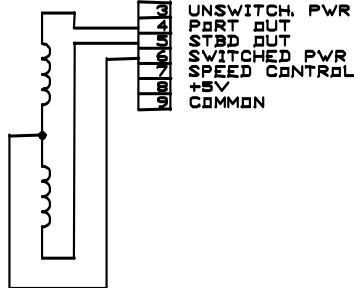

B) FOR FOUR-WAY VALVES, 12V DR WITH JGG LEVERS

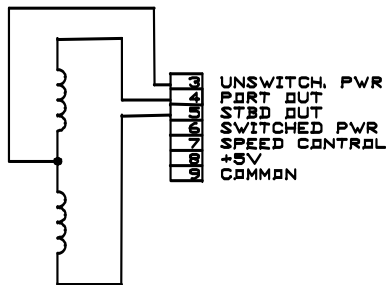

C) FOR AC SOLENOIDS

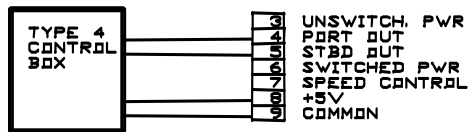

D) FOR CONTROLLING THE CLUTCH OF A ROTARY DRIVE OR THE LOCKUP VALVE OF A LINEAR ACTUATOR OR THE FIELD OF A WOUND MOTOR.

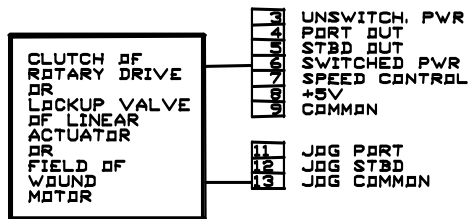

E) FOR PERMANENT MAGNET, SHUNT FIELD AND COMPOUND REVERSING MOTORS VARIABLE SPEED CONTROL

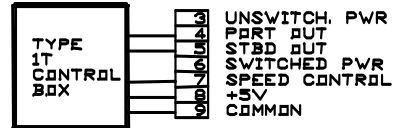

F) FOR PERMANENT MAGNET REVERSING MOTORS SINGLE SPEED CONTROL

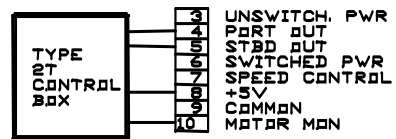

G) FOR SPLIT FIELD REVERSING MOTORS (ie WOOD FREEMAN 11/15)

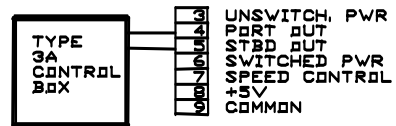

H) FOR CONTROLLING THE HIGH SPEED VALVE (STD. OR 4-WAY) OF A 2 SPEED DRIVE

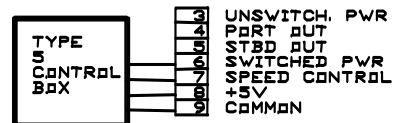

CompuNav Systems Ltd.

Title		
1001 AUTOPILOT INTERCONNECTIONS		
Size	Document Number	REV
B	1001INT.SCH	2
Date: December 13, 1991 Sheet 1 of 1		

DRIVE SYSTEM OPTOINS

OPTIONAL DRIVE SYSTEMS

- | | |
|-----------------------------------------------------------------------------------------------------------------------------------------------------------------------------|------------------------------------------------------------------------------------------------------------------------------------------------------------------------------|
| For all commercial and pleasure vessels over 50 ft where heavy usage will be the norm (hydraulic steering): | - CPUFC Flow Control Uniblock
12, 24 or 32 VDC
or
- CPUTS & CT5 - Two Speed Uniblock
12, 24 or 32 VDC
And
- Belt Driven Pump
Or
- Direct Driven Pump |
| For vessels with hydraulic cylinder displacements from 7 to 18 cu.in.): | - 18CI Reversing Motor Pump &
CT2-20A Drive Box (12 or 24 VDC) |
| For vessels with hydraulic cylinder displacements from 15 to 30 cu.in.): | - 30CI Reversing Motor Pump &
CT2-20A Drive Box (12 or 24 VDC) |
| For vessels with hydraulic cylinder displacements from 30 to 60 cu.in.): | - 60CI Reversing Motor Pump &
CT2-20A Drive Box (12 or 24 VDC) |
| For pleasure vessels with mechanical steering up to 70 feet: | - Hydraulic Linear Actuator &
CT2-20A Drive Box (12 or 24 VDC) |
| To retrofit to vessels with an existing autopilot drive system which uses a 2 wire (permanent magnet), 4 wire (shunt field), or 5 wire (compound) reversing electric motor: | - CT2-20A or CT2-40A Single Speed
Reversing Electric Motor Drive |
| To retrofit to vessels with an autopilot drive system using a 3 wire (split field) reversing electric motor: | - CT3 Split Field Reversing Electric Motor
Drive Box |
| To retrofit to vessels with an autopilot drive system using a 12 or 24 VDC solenoid operated 4-way valve: | - Nothing Extra Required (consult factory
on 32 VDC systems) |
| To retrofit to vessels with an autopilot drive system using a 110 or 220 VAC solenoid operated 4-way valve: | - CT4 AC Solenoid Drive Box
(100 to 240 VAC) |
| To retrofit vessels with an autopilot drive system using proportional valve: | - CT6 or Z-Drive Isolation Amplifier
(consult with factory) |

Regardless of the type of drive unit being used, the hardover to hardover time must be checked. For peak performance this time must be 10 - 15 seconds.

INSTALLATION INSTRUCTIONS AUTOPILOT

The autopilot is normally mounted in the vessel's wheelhouse. It can also be mounted in a more exposed location, such as the flying bridge of a sports fisherman, (*if it is flush mounted and the rear of the autopilot is protected from spray*).

Select either the bag containing the flush mount bezel and cutting template, or the bag containing the mounting bracket and knobs.

BRACKET MOUNT

- Position the mounting bracket so that the front of the autopilot will be easily visible. There must be a minimum of three inches (76 millimetres) of clearance behind the autopilot to allow for cabling.

- Screw the knobs part way into the threaded holes on both sides of the autopilot rear cover. Insert the autopilot into the mounting bracket, making sure that the rubber spacer is between the cover and the bracket, and the plastic one is between the bracket and the head of the knob. Tilt the autopilot to the desired angle, and tighten the knobs securely.

FLUSH MOUNT

- Ensure that there is at least five inches (127 millimetres) of depth in the mounting cavity to allow clearance behind the autopilot for cabling.

- If the autopilot is being flush mounted in an exposed location, care should be taken to ensure that the rear of the autopilot is not exposed to salt spray or other moisture. *The flush mount bezel reduces the effectiveness of the sealing gasket on the rear of the autopilot.*

- Position the cutting template on the panel where the autopilot is to be mounted, and mark the opening onto the panel. Cut the opening in the panel around the outside of the markings. *To improve the seal on the rear of the autopilot, an extra gasket for the rear cover has been supplied.*

- Unscrew the two large screws from the rear of the autopilot and remove the rear cover. Peel the protective backing off the extra gasket, and carefully position it on top of the one already in the rear cover.

- **Apply the protective gasket to the back of the flush mount bezel.**

- Slide the flush mount bezel over the autopilot chassis, and replace the rear cover and screws. Tighten the screws only enough to slightly compress the gaskets. Slide the autopilot into the hole in the panel, and mark the positions of the four mounting holes. Use the supplied screws to mount the autopilot.

- If you have access to the rear of the mounting panel, the autopilot can be easily removed from the panel by simply unscrewing the two large screws in the rear and sliding the autopilot out, without having to remove the bezel from the panel.

- The autopilot is supplied with a cover over the remote control receptacle on the back. If the receptacle is unused, the cover should be left on. The receptacle is weather-resistant only with the cover on or when a plug is connected to it. **Damage caused by exposing a receptacle to the elements will NOT be repaired under warranty.**

COMPASS

FOR COMNAV FLUX-GATE COMPASS

- The compass **MUST** be mounted as close as practical to the vessels centre of pitch and roll. *This is typically low in the vessel, at about the waterline, and slightly aft of the centre of the vessel.*
- You must keep the compass at least three feet away from engines, electric motors, and other magnetic objects. If this is not possible, their effects may be compensated for as described in the SEA TRIALS section of this manual.
- To reduce or eliminate the effect of the vessels vertical field, a HEELING ADJUST control is provided on the ComNav Fluxgate Compass, (although the sensitivity to the earth's vertical magnetic field remains.)
- Because of the sensitivity of the fluxgate compass to the earth's vertical magnetic fields, it is **NOT** recommended for use at latitudes higher than 50 degrees (North or South).
- Use the HEELING ADJUST control on the compass to eliminate the effect of the vessel's vertical magnetic field as described in the SEA TRIALS section of this manual. The HEELING ADJUST control is turned OFF when it is in the centre of its travel.
- Plug the end of the cable into the compass receptacle on the rear of the autopilot. If the length of cable supplied with the compass is not adequate, obtain an extra plug-in length from your dealer. Cutting and splicing the compass cable is **NOT** recommended.

FOR OTHER FLUXGATE COMPASSES

- The autopilot can be used with a Fluxgate Compass which outputs DC Sine and Cosine signals of up to +/- 3 volts amplitude about a 0 to 6 VDC reference.
 - If the compass does not have a HEELING ADJUST control (i.e. other makes of fluxgate compasses), it should **NOT** be used on steel vessels either.
 - The interface has been tested with Fluxgate Compasses manufactured by KVH, Brookes and Gatehouse, and VDO. Some of these compasses have to be specially ordered in order to have the required DC Sine and Cosine outputs.
 - The autopilot has been supplied with a 10 ft cable which is plugged into the Compass receptacle on the rear of the autopilot. The other end of the cable is terminated in flying leads. *See 0 for colour & function of each lead.*
 - +12 Volts will appear on the wire connected to Plug Pin 7 when the autopilot is turned on. Up to 100 milliamps can be supplied by this wire to power the fluxgate compass.
 - If the compass is separately powered, the tinned ends should be cut off of the wires connected to Plug Pins 7 & 4. The wires should then be taped back against the cable to prevent accidentally shorting out the +12V power supply inside the autopilot.
- Any other unused wires should also have their tinned leads cut off and be taped back against the cable.

CONNECTION FOR NON-1001 FLUXGATE COMPASSES

PLUG PIN NUMBERS	1001 FLUXGATE	COMNAV FUNCTION	NON-COMNAV CONNECTIONS
1	BLUE	COSINE	COSINE *
2	RED	DRIVE P1	N/C
3	BLACK	DRIVE P2	N/C
4	SHIELD	GROUND	GROUND
5	WHITE	REFERENCE	REFERENCE
6	YELLOW	SINE	SINE *
7	GREEN	+12V	+12V

* If the reading is reversed, swap these two wires.

- In testing, the Brookes and Gatehouse Halcyon 3 compass proved to have a 'floating' reference. The reference from the autopilot is also 'floating'. In order for the interface to work, one of the references must be fixed to a voltage. The reference is fixed to +2.5 Volts inside the autopilot by selecting Compass Type 3 (CPS.3) during the Dockside Set-up. Compass Type 2 (CPS.2) should be selected for all other fluxgate compasses.

- If the reading on the Digital Display of the autopilot increases when the heading of the vessel is decreasing, reverse the Sine and Cosine leads.

- If the reading on the autopilot display does not agree with the vessel's actual heading, place the Master Select Switch on the autopilot in the **STANDBY** position and press the **ADJUST** key twice to display the compass offset. Then press either the up or down **ARROW** key to adjust the offset by the amount of the error.

- If the compass is self-compensating, do not run the autopilot compensation routine during Dockside Set-up (press either the up or down **ARROW** key when 'CAAdJ' is shown on the display).

- If the compass is not self-

compensating, run the autopilot compensation routine to correct the compass during Dockside Set-up (press the **ADJUST** key when 'CAAdJ' is shown on the display).

MAGNETIC COMPASS

- The advantage of using a magnetic compass with a fluxgate sensor is that the autopilot is sensing the position of the magnets on the compass card rather than sensing the earth's magnetic field directly.

- As the card of the compass has physical inertia, it does not react immediately to the changes in the magnetic field it is immersed in, but only to those changes which persist long enough to overcome the resistance of the compass card to movement.

This means that the compass is a more stable heading reference than a fluxgate compass. The magnetic compass will largely ignore changes in the magnetic field in the plane of the compass card caused by vessel motion that the fluxgate compass will react to.

This is particularly important in high latitudes, (such as Alaska, Labrador or the North Sea), where the horizontal component of the earth's magnetic field (which is the portion the compass is trying to detect) is very small relative to the magnetic field of the vessel.

- The disadvantage of the magnetic compass is that in very rough weather with the vessel going to windward, it is possible for the vessel motion to upset or 'tumble' the compass card, disabling the autopilot.

- Because of the relative insensitivity of the magnetic compass to both the earth's and the vessel's vertical magnetic fields, (due to its inertia), it **IS** recommended for use at latitudes higher than 50 degrees (North or South), **AND** for use on steel vessels when the optional quadrantal spheres are included.

- Locate and mount the compass in a position which minimizes magnetic interference. **It should be at least three feet away from such equipment as radios, radars, depth sounders, and engine instruments.**

- The compass can be used as a steering compass if desired. If the amount of cable supplied is too short to reach the rear of the autopilot, obtain an extra plug-in length of cable from your dealer. **Cutting and splicing the compass cable is NOT recommended.**

- To reduce the possibility of the card 'tumbling' in rough weather, mount the compass as close as practical to the centre of pitch. **Mounting the compass far forward under a bunk or similar location is a poor choice for rough weather performance.**

IMPORTANT

It is important to remember that the compass is a vital part of the autopilot system. Locating it properly, particularly on steel hulled vessels, is essential to ensure proper operation of the autopilot. We recommend that the services of a qualified compass adjuster be used to select the best installation location and to compensate the compass properly for deviation, including that caused by heeling error. Care must be taken not to place compensating magnets too close to the compass, as this will cause the Fluxgate Sensor, mounted underneath the compass, to read incorrectly. To correct compass deviation on steel vessels, or on other vessels with magnetic compensating problems due to interference from adjacent iron masses such as an engine block or winches, the use of a pair of 3-1/4 inch (83 millimetre) Compensating Quadrantal Spheres is recommended.

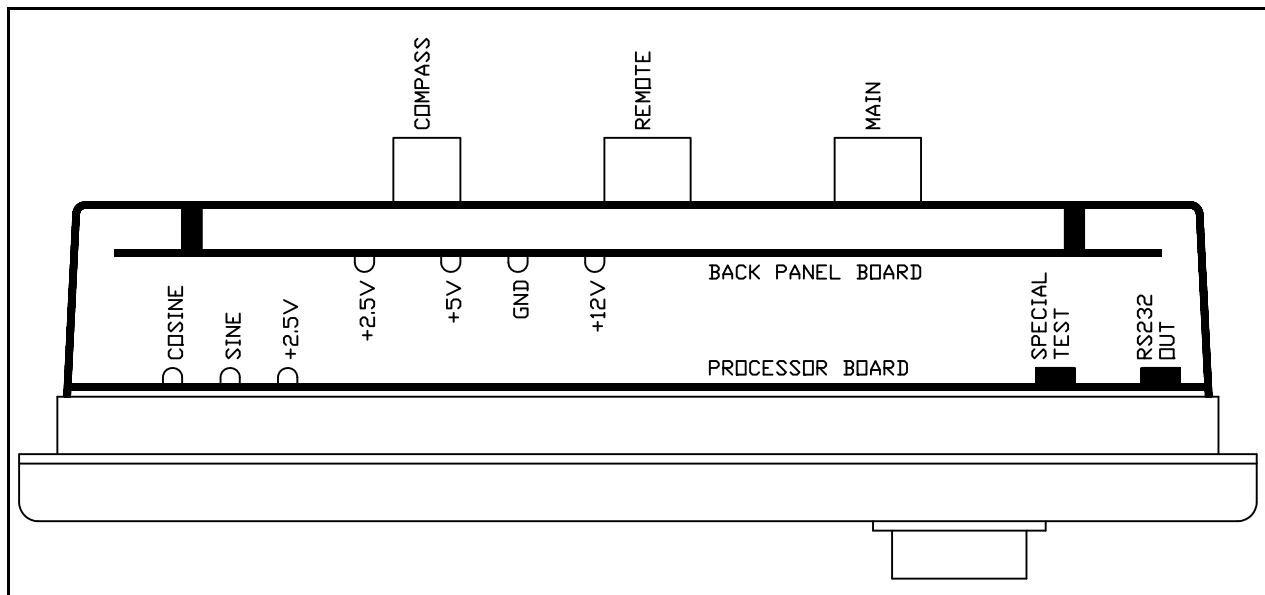

Figure 4 - Test Points

MOUNTING THE SENSOR TO NON-STANDARD COMPASSES

The fluxgate sensor supplied with the autopilot can be mounted to a wide variety of "externally gimballed" compasses. The sensor should not be mounted to "internally gimballed" compasses (where the compass card is gimballed and the bowl of the compass is not), because the compass card does not remain parallel to the sensor when the vessel rolls or pitches, resulting in large errors between the compass and autopilot.

Mounting the sensor above the compass reduces the possibility of compensating magnets interfering with the operation of the sensor, but also reduces the visibility of the compass if it is to be used as a steering compass.

Remove the rear cover from the autopilot. Fasten a pair of voltmeter probes between the SIN and +2.5V testpoints on the Processor Board (*see figure 4*).

Turn the master select switch on the autopilot to the **STANDBY** position. Hold the sensor either above or below the compass, and rotate it until a maximum level is observed on the voltmeter.

Move the sensor towards or away from the compass until a new maximum level is observed. This is the optimum distance from the compass to mount the sensor. Any closer and the sensor may interfere with the operation of the compass.

The accuracy of the sensor, and its sensitivity to external fields, will slowly weaken as it is moved further from the compass. If the reading on the autopilot display decreases when the heading on the compass is increasing, turn the sensor over. Rotate the sensor until the heading on the display of the autopilot matches the reading on the compass, and tighten the mounting screw.

Rotate the compass through 360 degrees, comparing readings every 20 degrees. The readings should agree within +/- 2 degrees (4 degrees total error) if the compass is compatible with the sensor.

As a further test, tilt the bowl of the compass so the card tilts relative to the sensor. The heading on the display of the autopilot should not change more than two degrees, with the compass still indicating the same heading.

If the heading changes more than two degrees, the magnets on the compass card are not powerful enough, and the compass is not compatible with the sensor.

If the accuracy of the compass and sensor combination cannot be made at least +/- 2 degrees, then the compass is not compatible with the autopilot sensor. Your dealer can supply a compass specifically designed for the ComNav 1001 autopilot.

DISTRIBUTION BOX

Position and mount the distribution box underneath or inside the control console in a DRY location so that the main cable from the distribution box will easily reach the rear of the autopilot. Cables are inserted into the distribution box by filing or cutting out the pre-formed ports in the cover. To ensure a neat appearance, the cover has only had the minimum number of openings prepared in advance.

The suggested types and gauges of cables required to hook up the autopilot are listed in Table II.

The functions of each set of connections in the distribution box are as follows:

- 1. POSITIVE PILOT POWER (+)**
- 2. NEGATIVE PILOT POWER (-)**

These two terminals should be hooked to a source of DC power on the boat. The voltage can be from 10 to 27.5 VDC. The maximum current requirement is less than 4 amps. The autopilot is negative ground.

For vessels with positive ground, or with multiple power sources (i.e. AC and DC power sources) the autopilot control head should be electrically isolated from the vessel. This can be accomplished by mounting it to a non-conducting material, such as wood or fibreglass. This will prevent any damage from ground currents.

The power should be taken directly from a breaker or power distribution panel. The autopilot should have its own circuit. This circuit can also send power to the drive unit.

If the drive unit is a reversing electric type, it should be wired back to the breaker separately from the autopilot (i.e. do **NOT** wire from the breaker to the drive unit, and then from the drive unit to the autopilot). The combined current requirement of the autopilot and any reversing electric drive unit manufactured by ComNav Marine will not exceed 30 amps.

3. UNSWITCHED POWER

The input voltage appears on this terminal at all times when the breaker which supplies power to the autopilot is on. If a 12 VDC solenoid operated 4-way valve is being used, wire this terminal to the common of the solenoid valve to ensure an adequate voltage supply.

If Jog Levers are being used, and are to be active even with the autopilot turned off, wire this line to the common of the solenoid operated 4-way valve.

WARNING

If the UNSWITCHED PWR terminal is used and there is a malfunction of the autopilot or jog lever which continuously activates the 4-way valve, the only way to deactivate the 4-way valve is to turn off the breaker which supplies power to the autopilot.

4. PORT STEERING OUTPUT

5. STBD STEERING OUTPUT

These are the two main steering outputs from the autopilot. They are **open collector** (i.e. switch to ground) and can sink up to 3 amps of current. They can be used directly to operate a solenoid operated hydraulic 4-Way Valve, or as inputs to a solid state drive box for electric steering systems (either hydraulic or mechanical).

Either output can be overridden with a switched connection (such as a jog lever) between JOG PORT or JOG STBD and JOG COM (terminals 11, 12, and 13) without damaging the autopilot. A pair of diagnostic LED's, one red and one green, are provided in the distribution box to confirm the correct operation of these two outputs.

6. SWITCHED POWER

The input voltage appears on this terminal when the autopilot is in any mode except **STANDBY** or **OFF**. It can supply up to 3 amps of current for use as the power source for a solenoid operated 4-Way Valve, or to activate an electric steering system.

A yellow diagnostic LED is provided in the distribution box to confirm the correct operation of this output. For 12V 4-Way Valve operation, it is recommended that this output not be used; instead, the common lead from the solenoids should be connected to UNSWITCH. PWR (terminal 3).

7. SPEED CONTROL

This is a linear signal used with variable speed drive systems. It is centred between +5 VOLTS and COMMON (terminals 8 and 9) when no change of rudder angle is required, and moves up or down from that point by as much as 2.5 VDC for maximum rudder position change to port or starboard respectively.

8. +5VDC

9. COMMON

+5 volts appears across these terminals whenever the autopilot is turned on. These terminals are used by several of the Drive Boxes manufactured by ComNav Marine as a reference for SPEED CONTROL (terminal 7).

A yellow LED is provided in the distribution box to confirm the operation of the 5V power supply in the autopilot. Terminal 9 must **NOT** be used as the return for a motor field or the clutch or a rotary drive or the lockup valve of a linear actuator; JOG COMMON (Terminal 13) or PILOT POWER (-) (Terminal 2) should be used instead.

10. MOTOR MONITOR

This terminal is used with some of the Drive Boxes manufactured by ComNav Marine to monitor motor current. If the current exceeds a maximum level, the autopilot will sound an alarm.

11. JOG PORT

12. JOG STBD

13. JOG COMMON

If any jog levers are being used in the system, they should be connected to these three terminals. If the jog levers are to be active all the time, whether the autopilot is turned on or off, connect the common from the solenoid valve to UNSWITCHED POWER (terminal 3).

14. RUDDER POWER

15. RUDDER POSITION

16. RUDDER COMMON

These three terminals connect to the rudder follower. With the cable from the distribution box unplugged from the rear of the autopilot, and the rudder turned to dead ahead, the resistance between RUDDER POWER and RUDDER POSITION, and RUDDER POSITION and RUDDER COMMON should be equal, and each measure approximately 600 ohms if you are using a ComNav Rudder Feedback.

17. NAV SIGNAL

18. NAV RETURN

These two terminals connect to the NMEA 0183 output of a Loran C Receiver, GPS Receiver, or other type of navigation device so equipped. Whenever the autopilot is turned on, the LED next to these terminals will light while data is being received.

19. RAI SIGNAL

20. RAI RETURN

These two terminals are used to run up to three ComNav Marine rudder angle indicators. Multiple rudder angle indicator installations must be wired in series. If all the indicators move to port when the rudder is moving to starboard, reverse the connections to these terminals. If only one of the indicators moves to port when the rudder is moving to starboard, reverse the connections at that indicator only. Use the ZERO ADJUST potentiometer on the Distribution Box circuit board to make the indicators read zero degrees when the rudder is dead ahead.

Table II - RECOMMENDED CABLES

USE	TYPE
Pilot Power	2 X 16 GAUGE
-Steering Drive- 12/24/32VDC Solenoid Valve	3 X 18 GAUGE
-Steering Drive- CT2,CT3,CT4, CT5 and CT6 Drive Box	Refer to the Instructions Supplied with Drive Box
Rudder Follower	3 X 18 GAUGE
Navigation Interface	2 X 24 GAUGE with OVERALL SHIELD. Shield terminated at the Nav Device ONLY
Rudder Angle Indicator	2 X 24 GAUGE

RUDDER FOLLOWER

The rudder follower is used to transmit the position of the rudder back to the autopilot. It should be connected to whatever part of the steering system the autopilot controls. Normally, this will be the vessel's rudder. However, if the vessel has 2 stage steering, such as Wagner M10, Kobelt Power Steering or a similar system where the autopilot drives a control or servo ram, the rudder follower should be mounted to the servo ram rather than to the rudder. If the rudder follower is connected directly to the rudder in this case, uncontrollable hunting of the rudder will result.

Normally the rudder follower is mounted in the stern of the vessel, close to the rudder post. A mounting base may have to be fabricated to position the rudder follower properly. Mount the follower in a location where the possibility of damage from any equipment stowed in the area is minimized.

If a Medium Duty rudder follower was supplied:

Mount the rudder post arm on the rudder post using a stainless steel band clamp (not supplied). Bolt the ball joint to the hole in the rudder post arm corresponding to the diameter of the rudder post in inches, making sure the ball is facing upwards (see Figure 5). Mount the rudder follower so that the rudder follower arm is the same height as the rudder post arm. The rudder follower is centred when the arm is directly above the cable gland. (See figure 6 for alignment details.)

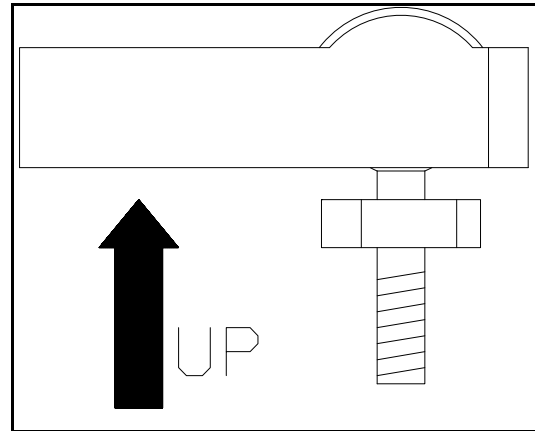

Figure 5 - Correct Linkage Orientation

If a Heavy Duty rudder follower was supplied

Mount the rudder follower so that the top of the vessel's tiller arm is 1 3/4 inches lower than the top of the rudder follower arm. On the centerline of the vessel's tiller arm, and within 3 to 5 inches from the centre of the rudder post, either:

- drill and tap a hole 1/4-20
or

- drill a clearance hole for a 1/4 inch bolt if enough of the threads of the supplied ball joint will come through the tiller arm to permit the supplied nut to be threaded onto it.

The rudder follower is centred when the arm is pointing away from the cable gland and is directly over the stainless rivet in the top cover. (See Figure 6 for alignment details.)

With either rudder follower.

The distance between the centerline of the rudder post and the rudder follower must not exceed 24 inches. Make sure that the ball joints on the rudder arm and rudder follower arm are facing upwards as shown in Figure 4. Snap the rod assembly onto the ball joints. Be sure to close the release clamps on each socket. Refer to Figure 5 or Figure 6 and adjust the length of the rod to get the correct geometry with the rudder dead ahead.

If the length of cable supplied is too short to reach all the way to the distribution box, obtain a terminal strip and sufficient additional cable from your dealer. Mount the terminal strip in a convenient DRY location. Connect the rudder follower cable to the terminal strip and then the additional length of cable. Strip the wires, and attach them to the terminals in the distribution box as shown *Table III*

Table III - Rudder Follower Cable Connections

Colour	Terminal	Description
White	14	+5V
Green	15	POS'N
Black	16	COM
Shield	2	GND

If the locking screw in the rudder follower arm has been loosened, or the arm removed from the rudder follower, re-attach the arm and check the potentiometer centring. When the rudder is dead ahead, the electrical resistance between the Black and Green wires and the White and Green wires should be equal (approx. 600 ohms each).

Be careful to check the installation for any mechanical obstructions or binding of the linkage, and correct it now, before it becomes a problem.

The rudder follower is supplied with 50 feet of cable. Run the cable from the rudder follower towards the distribution box, ensuring that it is protected by hose or conduit wherever it passes through fish or cargo holds, or any other area where it could be damaged.

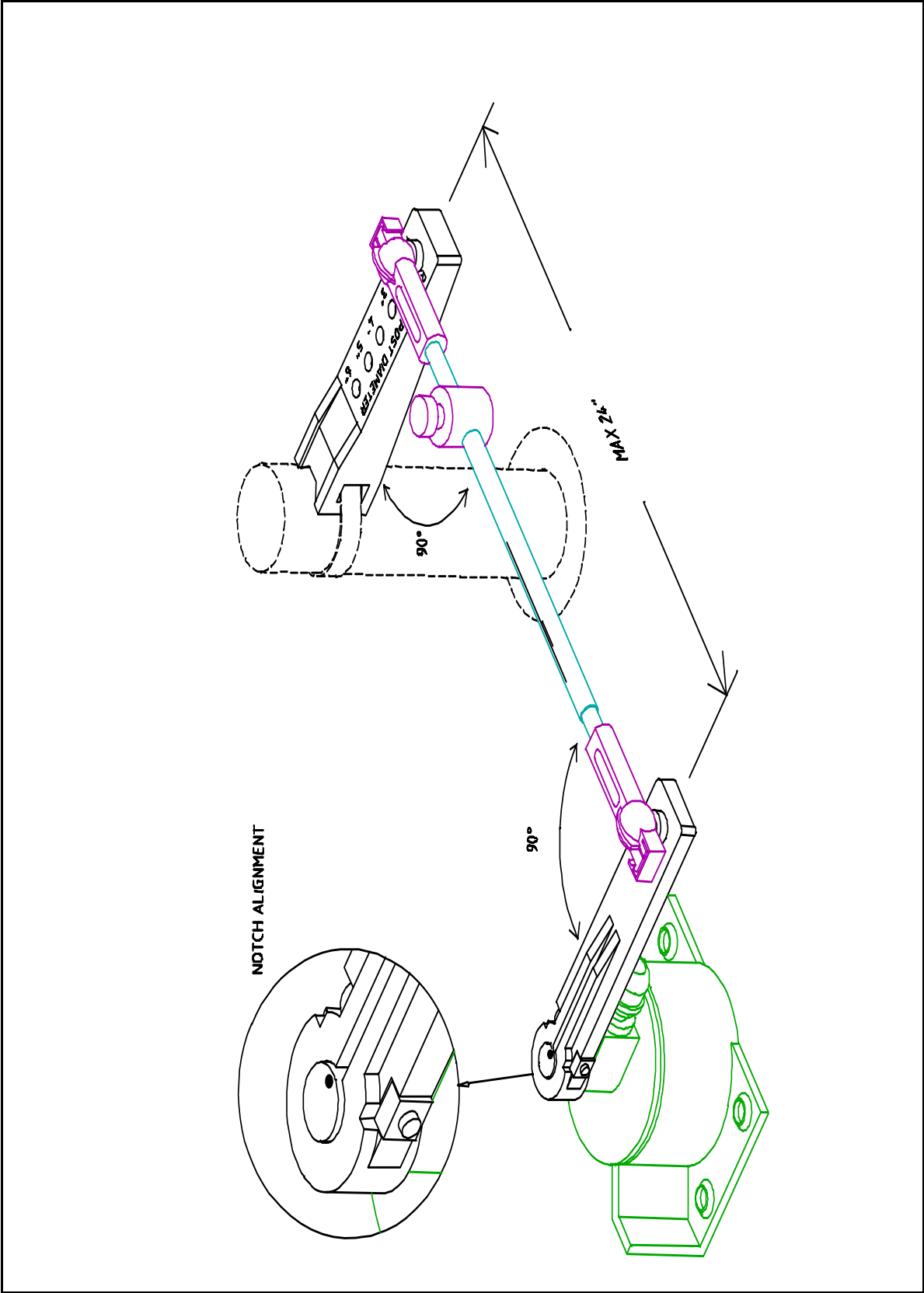

Figure 6 - Rudder Feedback correctly installed to rudder post

NAVIGATION INTERFACE

If the autopilot is being interfaced to a navigation device with several NMEA outputs, determine the type of output formats available from its data sheets. The 1001 autopilot will only support NMEA 0183 data format and therefore that format must be selected. If your navigation device only outputs 0180 or 0182 formats, please consult with ComNav service personnel to receive software that will support these older style formats.

NMEA 0183

The standard baud rate for the 0183 data format is 4800 baud.

This data format was developed to allow a number of pieces of electronic equipment on the vessel to communicate with each other. It consists of a large number of data 'sentences' which can transmit anything from the vessel's water speed to its present position from one device to another.

A data sentence consists of a two letter identification of the sending device, followed by a three letter identification of the data sentence, followed by the corresponding information.

The autopilot can understand a number of data sentences that contain steering or speed information. The autopilot ignores the two letter device identifier, and only looks for the three letter sentence identifier, so it will receive information from any Nav Device which transmits the correct data sentences.

Some NMEA 0183 data sentences supply heading from the beginning of track to the end of the track, which remains constant until the Nav Device sequences to the next waypoint. This is the best type of Heading To Steer information, as it prevents the wandering which may occur when the vessel is close to the destination waypoint as described earlier.

Depending on the type of Nav device and how it is configured, the autopilot may sound its alarm and display 'Arr' when the vessel is close to a waypoint.

The variations of NMEA 0183 which are currently supported by the autopilot along with the information the autopilot uses from that sentence are listed below:

RMA	Loran C Navigation Information - Receiver Status plus Vessel Speed plus Variation
RMC	GPS Navigation Information – Receiver Status plus Vessel Speed plus Variation

The RMA or RMC data sentence is always combined with the RMB data sentence.

RMB	Generic Navigation Information - Cross Track Error plus Heading To Steer from vessels present position to the end of the track (Degree's True only).
APB	Autopilot Interface Format - King Version - Cross Track Error plus Heading To Steer from the vessel's present position to end of track.
APB	Autopilot Interface Format - NMEA Version - Cross Track Error plus Heading To Steer from the vessel's present position to end of track.
APA	Autopilot Interface Format - Cross Track Error plus Heading To Steer from beginning to end of track.
XTE	Cross Track Error - Cross Track Error plus Receiver Status.

XTE is always combined with one of the following:

BOD	Bearing Origin to Destination – Bearing from the beginning of the track to end of the track. This is the preferred heading format, or;
WBD	Waypoint Bearing and Distance – Proprietary output from Northstar Lorans. Heading to Steer is from the vessel's present position to the end of the track;
HSC	Heading Steering Command – Heading To Steer from the vessel's present position to the end of the track.

The vessel's speed is read from the RMA or RMC data sentence or one of the

following:

VBW	Vessel Speed relative to water from Dual Doppler Speed Log.
VHW	Vessel Heading and Water Speed
VTG	Vessel Track and Ground Speed

CROSS TRACK ERROR RESPONSE

The response of the autopilot is set with the master select switch in the **NAV** position.

Press the **TURN** key, and then the green **ARROW** key to select normal *indicated by an 'n' on the right of the display*, or reversed *indicated by an 'r' on the right of the display* response to cross track error.

If the setting is incorrect, the vessel will initially turn to the correct heading, but then as some cross track error develops, the vessel will continually turn further and further away from the correct heading to the waypoint.

Cross Track Error contains two pieces of information; the amount of the error, and the 'sense' of the error (i.e. whether the vessel is to the Left or the Right of the line between the beginning and ending waypoints).

The NMEA *National Marine Electronics Association* has specified how the cross track error should be identified (i.e. a (L)eft indicator in the data sentence means the vessel should steer to the left and a (R)ight indicator meaning the opposite).

However, some manufacturers have used the (L)eft indicator to mean that the vessel is to the left of the line, which means the vessel should steer to the right, and the (R)ight indicator to mean the opposite.

Because of this confusion, the response of the autopilot to cross track error can be switched from 'Normal', meaning the vessel will respond normally to the sense of the cross track error, to 'Reversed', meaning the vessel will respond the opposite way in response to the same information.

CHECKSUM EVALUATION

During testing it was discovered that some Navigation Devices incorrectly calculate the checksum, causing the checksum error message to be displayed repeatedly.

The checksum evaluation can be turned off by turning the master select switch to STANDBY and press the **ADJUST** key repeatedly until 'cn:ON' is displayed. Press either the up or down **ARROW** key until 'cn:OF' is displayed.

The RMA, RMB and RMC data sentences contain a 'checksum' which is determined by the contents of the sentence. The autopilot can calculate what the checksum should be and compare it to the sentence. If the sentence was received correctly, the two checksums should be the same. If they are different the autopilot assumes that the sentence was incorrectly received and displays 'cn:Er'.

**** IMPORTANT ****

If you have installed a ComNav Marine reversing motor pump, a constant running pump or an engine driven pump, there are several checks that must be done during the first several weeks of usage in order to prevent poor or dangerous steering performance. During this period you must check for air or leaks in your hydraulic system.

Residual air in your steering system

Following the initial installation and bleeding of your ComNav pump, some residual air may remain suspended in the hydraulic fluid. During the first few weeks, this air will gradually bleed out through the header tank or the highest helm pump and the oil level may go down. Check several times and add more oil as required.

Leaking fittings or equipment

Following the initial installation and bleeding of your ComNav pump continuously monitor the oil level of the reservoir or the highest helm pump in your steering system and add oil as required. If this condition persists, it may be an indication of leakage in your steering system. Check all hydraulic steering fittings and equipment for leakage.

DOCKSIDE SET-UP

INTRODUCTION

It is essential that the DOCKSIDE SET-UP procedure be performed before taking the vessel out on the water.

This procedure will be much easier to do if you have a helper, especially if you don't have a rudder angle indicator (R.A.I.).

The goals of the dockside set-up are:

1. To set the limits of the rudder travel.
2. To adjust the R.A.I.
3. To configure the compass.
4. To make sure that the navigation interface is properly connected.

NOTES

Always turn the autopilot to OFF before making any changes to the wiring in the distribution box. Failure to do so could cause serious damage to the autopilot in the event of a dropped wire, a misconnection, or similar problem.

It is **VERY IMPORTANT** to manually turn

the rudder from hard over to hard over and check that the rudder follower does not hit anything and that the linkage does not bind. (Part of the dockside set-up consists of automatic rudder movements by the autopilot and damage could result if the rudder follower is installed incorrectly.)

SETTING OF RUDDER TRAVEL LIMITS

1. Turn the autopilot to OFF. Press and hold the ADJUST key on the autopilot front panel and then turn the autopilot on to STANDBY.

2. Release the key when '**r.SET**' is shown on the autopilot display. Press the ADJUST key briefly. The autopilot will show '**HO S**' on the display.

3. Manually turn the wheel hard over to starboard and then press the green ARROW key. The autopilot will then show '**HO P**' on the display.

4. Manually turn the wheel hard over to port and then press the red ARROW key.

If the autopilot detects a problem with the output from the rudder follower during this procedure, it will display the message '**rEdO**'. *If this happens turn the autopilot off and recheck the rudder follower installation as described in the INSTALLATION section of the manual. (In particular, check that the rudder follower is electrically centred when the rudder is dead ahead.)* **Start this section again.**

5. The autopilot will show '**Cntr**' on the display. Turn the wheel to approximately dead ahead using the wheel. Then press the **ADJUST** key.

The autopilot will turn on the starboard output for 2 seconds. *If the rudder moved to port, the autopilot will sound its alarm and flash the word 'Stbd' on the display.*

6. Turn the autopilot to OFF, reverse the PORT OUT and STBD OUT leads (terminals 4 and 5) in the distribution box. **Start this section again.**

7. If the hard-over to hard-over time (H.O. Time) is greater than 28 seconds in either direction, the autopilot will alarm and display 'SLOW' until the **ALARM CLEAR** key is pressed. *The autopilot will then complete the dockside set-up routine.*

Please note that no vessel will steer properly, especially in rough weather, with an H.O. Time over 28 seconds. For most vessels under 100 feet, we recommend that the H.O. Time be 8 to 16 seconds.

The smaller and faster the vessel, the faster the rudder should move.

For example a 30 foot high speed vessel should have an H.O. Time closer to 8 seconds, and an 80 foot low speed vessel would not require the H.O. Time to be faster than 16 seconds.

ADJUST RUDDER ANGLE INDICATOR (if installed)

Turn the master select switch on the autopilot to the STANDBY position.

Center the rudder.

Turn the wheel to port and then to starboard. If the rudder angle indicator moves to port when the rudder moves to starboard, reverse the RAI SIGNAL and RAI RETURN leads (terminals 19 & 20) in the distribution box.

If the rudder angle indicator(s) do not read 0 degrees when the rudder is dead ahead, adjust the ZERO ADJUST potentiometer on the distribution box circuit board until they do.

CONFIGURING THE COMPASS

1. The autopilot will show 'C.SET' on the display, when the setting of the rudder limits is complete. Press the **ADJUST** key briefly and the display will change to show the type of compass to be selected.

CPS.1 is a magnetic compass and fluxgate sensor combination.

CPS.2 is a fluxgate compass with a fixed voltage reference output. *Most fluxgate compasses including ComNav Marine, KVH (Azimuth or Sailcomp) and VDO are of this type.*

CPS.3 is a fluxgate compass with a floating reference output. *The only compass of this type we know of is the Brookes & Gatehouse Halcyon III.*

2. Press either the up or down **ARROW** key until the type of compass selected is the same as the type of compass being used.

3. Press the **ADJUST** key. The display will change to show 'C.AdJ' if you have selected either CPS.2 or CPS.3.

As we don't want to swing the compass yet, press either the up or down **ARROW** key to exit from the set-up program.

To verify your heading, turn the master select switch to the **STANDBY** position. The display will show the vessel's current compass heading. If the heading displayed by the autopilot does not agree with the compass, press the **ADJUST** key twice to display the current heading offset, and then use the up or down **ARROW** key to adjust the offset by the amount of the error.

NAVIGATION EQUIPMENT INTERFACING

1. Turn on the Nav Device (GPS, Loran, Plotter, etc.) and wait for it to settle and extinguish all alarms.

2. Program a waypoint into the Nav Device, and start it navigating towards the waypoint.

3. Turn the Master Select Switch on the autopilot to the **NAV** position. The heading display on the autopilot should start to change towards the heading to steer as indicated by the Nav Device.

Press the **TURN** key once to see which type of data the autopilot is using to verify correct programming of the Nav Device.

If the autopilot display comes up with 'ndEr', it is not receiving any data from the Nav Device.

Check that the Signal and Return lines from the Nav Device are not reversed, and that the output from the Nav Device is set correctly if it is programmable.

Check that the data LED in the autopilot distribution box is blinking periodically.

If the interface still cannot be made to work, contact your dealer or ComNav Marine directly for assistance.

SEA TRIALS

The purpose of sea trials is to swing the compass, (CPS2 or CPS3) if it is a fluxgate compass, and to check the general operation of the autopilot.

CAUTION: A potentially dangerous situation can be caused by the addition or movement of magnets in the vicinity of the compass. This can result in actual deviations being different than those listed on the deviation card.

If the autopilot is using a magnetic compass and fluxgate sensor combination or a self compensating fluxgate compass (such as the KVH Autocomp 1000), *go to B.*

A) Turn the autopilot off.

Press and hold the **ADJUST** key and turn the autopilot on to **STANDBY**.

Release the key when the display shows 'r.SET'.

Press either the up or down **ARROW** key until the display shows 'C.SET'.

Press the **ADJUST** key. The display will switch to show the current type of compass selected (see DOCKSIDE SETUP). *This should already be correct.*

Press the **ADJUST** key again. The display will switch to show 'C.AdJ'.

Press the **ADJUST** key again. The display will switch to display 'turn'.

Slowly turn the vessel in one complete circle either to port or to stbd. This is best done with either the bowthruster or by placing one engine slow ahead and the other slow astern.

If the vessel has one engine and no bowthruster, slow ahead with the rudder half-way to hard-over is best. The turn should take more than one minute to complete.

When the circle is complete, the autopilot will beep and display first a North/South correction followed by an East/West correction.

If either correction is greater than 30, the compass should be moved and re-swung, or corrected manually by a qualified compass adjuster.

If you choose to correct the compass manually, use the following procedure:

Turn the autopilot off.

Press and hold the **ADJUST** key while turning the autopilot on to **STANDBY**.

Release the **ADJUST** key when the display shows 'r.SET'.

Press either the up or down **ARROW** key until the display shows 'C.SET'.

Press the **ADJUST** key. The display will switch to show the current type of compass selected. *This should be already correct.*

Press the **ADJUST** key. The display will switch to 'C.AdJ'.

Press either the up or down **ARROW** key to bypass the compass adjustment routine. All adjustments have now been turned off, and the raw compass information is now shown on the display. The compass adjuster can use this display to adjust the compass manually.

After the compass adjuster is finished, re-swing the vessel using the automatic method described above to remove any minor errors which may persist.

The ComNav Marine Fluxgate Compass, like most self compensating compasses, removes the effect of the deviating magnetic field, but does not actually remove the field itself.

If the field is sufficiently large, when the vessel rolls, the portion of the field in the plane of the sensor changes, and is interpreted as a turn by the compass, causing the vessel to wander.

The compass adjuster, by placing magnets around the compass removes the deviating field itself from the vicinity of the compass, resulting in much more accurate steering in all sea conditions.

Place the vessel on a known heading.

If the reading on the autopilot display disagrees with the vessels actual heading, correct it with a permanent heading offset.

To do this, place the master select switch in the **STANDBY** position, press the **ADJUST** key twice to display the heading offset, and adjust it up or down by the

amount of the error using the up or down **ARROW** keys.

The display will change back to show the vessels heading in 5 seconds, which should now be correct.

If the autopilot is using a ComNav Fluxgate compass, the final adjustment is the heeling adjustment.

To access the heeling adjuster, remove the screw from the top of the compass.

Reach in through the hole with a small non-magnetic screwdriver to make an adjustment.

This manual adjustment corrects for any vertical magnetism in the vicinity of the compass.

During the remainder of the sea trials, if the vessel seems to wander on some headings (particularly North or South) while steering well on other headings, turn the heeling adjustment clockwise or counter-clockwise until wandering stops.

This adjustment may cause some additional deviation in the compass, so the compass should be re-swinged using the automatic method after any change of the heeling adjustment.

B) The 1001 Autopilot offers instant selection of pre-adjusted FAST and SLOW vessel control settings. Adjust or fine-tune these settings to your vessel characteristics as follows:

FAST

Turn the master switch to **PILOT** position.

Press the **ADJUST** key once. If the display reads 'SLOW', press either the up or down **ARROW** key once so the display reads '**FAST**'.

Increase the vessels speed to its fastest normal cruising speed.

Make a 40 degree course change.

The vessel should settle onto the new course with one overshoot of 5 degrees or less.

If the vessel stops turning before the new heading is reached and then approaches it slowly, either increase the Rudder one level, or decrease the Counter Rudder one level and retest.

If the vessel overshoots the new heading, and then makes several turns across the new heading before settling down, either decrease the Rudder one level, or increase the Counter Rudder one level and retest.

See 0 for a graphic representation of correct vessel response during this manoeuvre.

Adjust the fast Turn Rate setting so the vessel makes course changes at a comfortable rate.

The factory pre-set adjustments are Rudder 3; Counter Rudder 3; Yaw 1, Turn Rate 6.

SLOW

Slow the vessel down to a slow cruise or to working speed.

Leave the master select switch in the **PILOT** position.

Press the **ADJUST** key once, and then press either the up or down **ARROW** key

so the display reads 'SLOW'.

Make several 40 degree course changes and use the instructions in the "FAST" section above to adjust the slow rudder and counter rudder settings.

See 0 for a graphic representation of correct vessel response during this manoeuvre.

Adjust the slow Turn Rate setting so the vessel makes course changes at an appropriate rate.

The factory pre-set adjustments are Rudder 5; Counter Rudder 5; Yaw 1, Turn Rate 6.

C) The Yaw (fast or slow) is normally left at '1'.

This provides 0.5 degrees of dead band on either side of the programmed course before the autopilot will begin to react.

On many vessels, setting the Yaw to '0' will cause the autopilot to work harder than necessary to hold the vessel on course.

As the weather deteriorates, the Yaw setting can be increased. *This will result in slightly worse steering, but will reduce the amount of rudder movement, prolonging the life of the steering system.*

D) **On board magnetic interference to the compass is likely the problem**, if the vessel steers properly under autopilot control on some headings, but seems to wander on others, particularly heading either North or South.

If the autopilot is using a ComNav Fluxgate Compass, try changing the heeling adjustment to reduce or eliminate the problem.

Remember to re-adjust the compass using the automatic method after any change of the heeling adjustment.

If this has no effect, return the heeling adjustment to the centre of its travel, turn off the automatic adjustment, and have a qualified compass adjuster compensate the compass. After the compass adjuster is finished, re-swing the compass using the automatic method, as described in Section A, to remove any small residual errors.

If the autopilot is using a different brand of fluxgate compass, or a magnetic compass with fluxgate sensor, a qualified compass adjuster will be required to reduce or eliminate this interference.

For best operation, in addition to normal adjustments, the compass should be compensated for deviation caused by heeling error (particularly on steel hulled vessels).

Adjustments of this sort should only be performed by a qualified compass adjuster.

TABLE IV

SETTINGS CHART						
Vessel Speed	Vessel State	Sea State	Rudder	Counter Rudder	Yaw	Turn Rate

CORRECT VESSEL RESPONSE

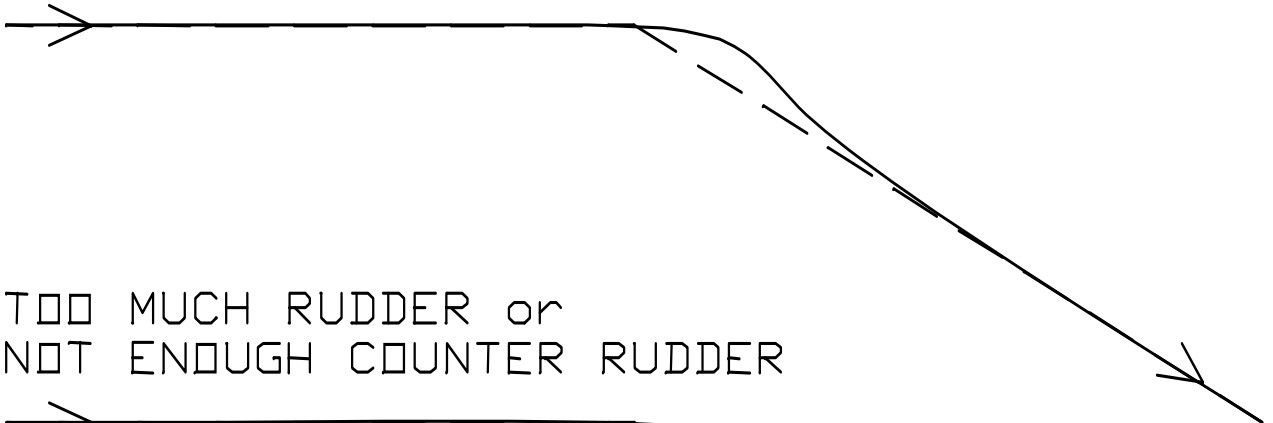

TOO MUCH RUDDER or
NOT ENOUGH COUNTER RUDDER

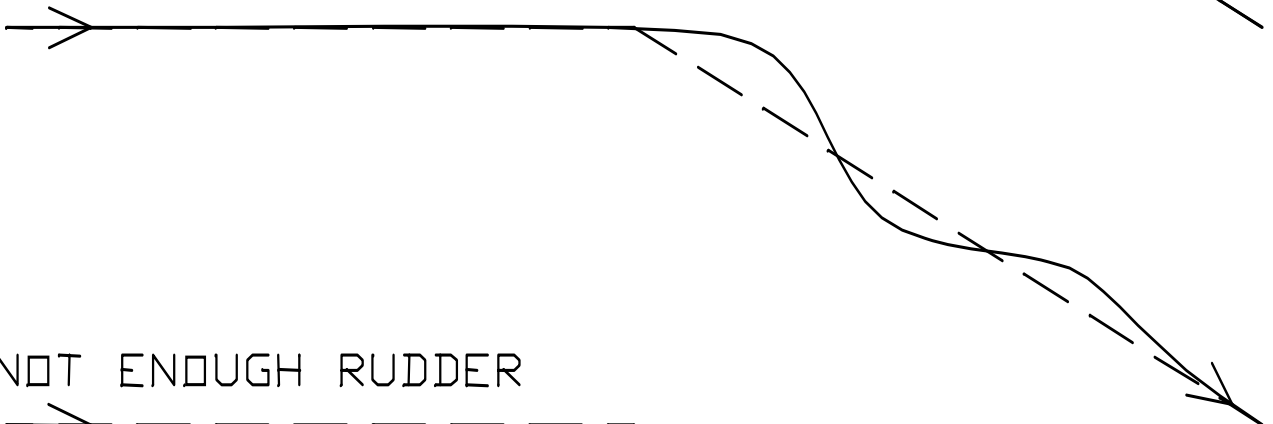

NOT ENOUGH RUDDER

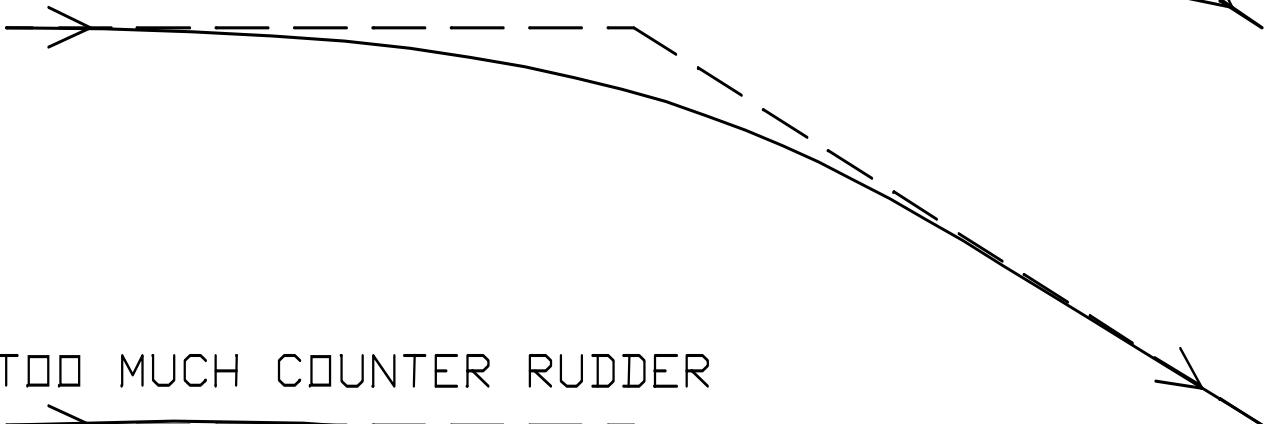

TOO MUCH COUNTER RUDDER

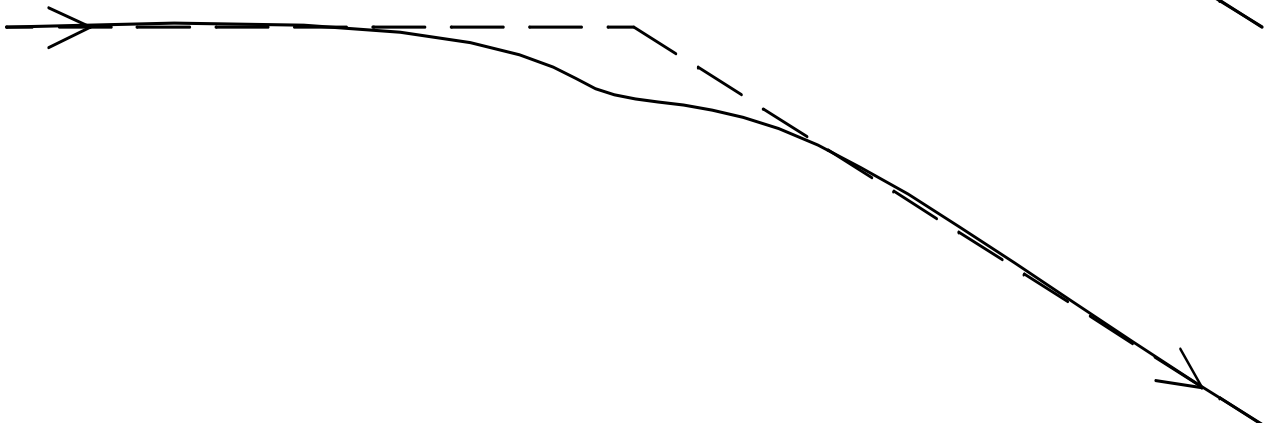

CONTROLS

The controls consist of a five position master select switch, and a 9 position membrane keypad. The controls operate as follows:

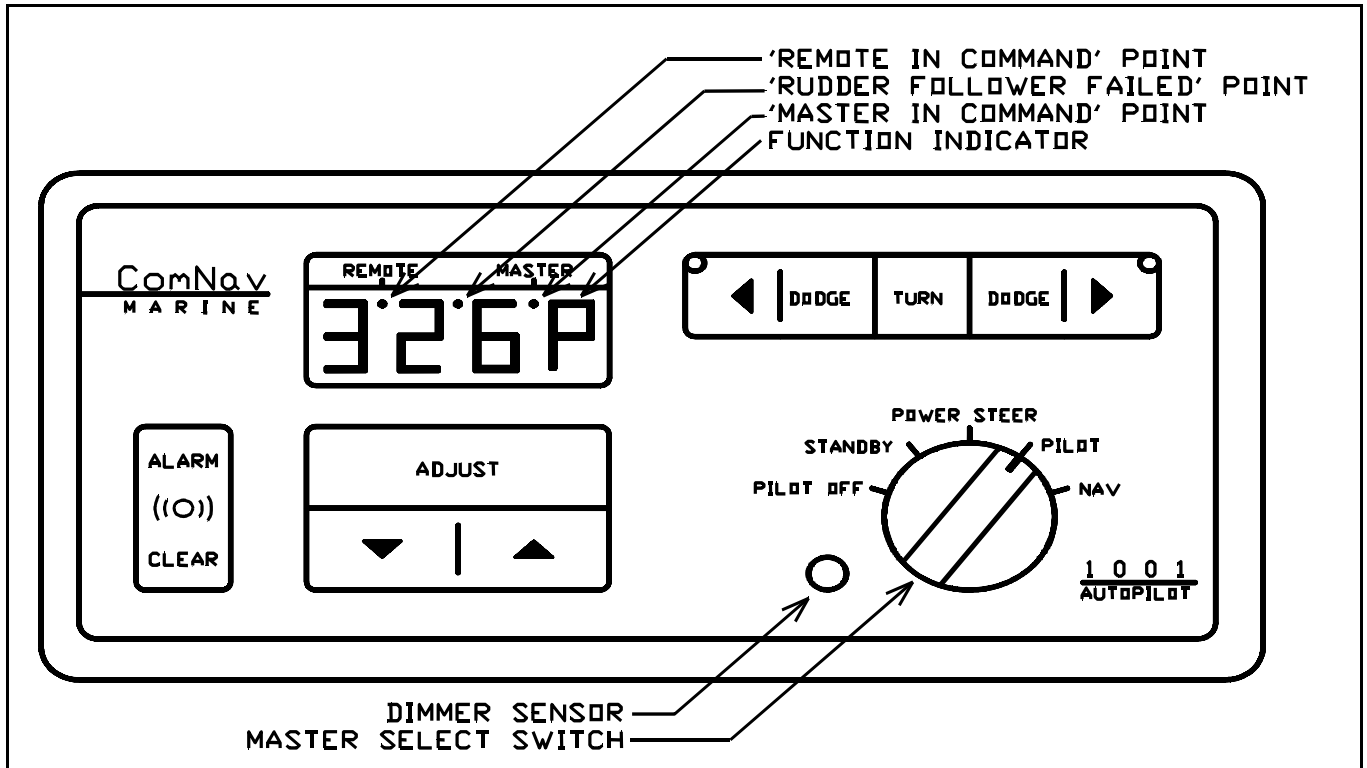

MASTER SELECT SWITCH

OFF

All power to the autopilot is turned off. The display will be blank.

STANDBY

356'

The left three digits of the display show the vessel's current compass heading. This is the mode the autopilot must be in to adjust various pre-sets, such as speed sensitivity, compass heading offset, minimum brightness, type of special turn selected or to initiate a full reset.

POWER STEER

356°

The left three digits of the display show the vessel's current compass heading. The vessel can be steered by using the red and green **DODGE & ARROW** keys to turn the rudder port or starboard as desired.

The display will switch to show the vessel's rudder angle whenever a red or green key is pressed. The display will continuously show the vessel's rudder angle if the **TURN** key is pressed. Compass information can be returned to the display by pressing the **TURN** key again.

PILOT



The vessel will steer the course indicated on the left three digits of the display.

The course the vessel is steering can be changed by pressing either the red or green **ARROW** keys.

Pressing and releasing either key will change the heading by one degree.

Pressing and holding either key will initially change the vessel's heading by one degree and after a one-half second delay, by ten degrees per second until the key is released. The function display will show a 'c' until the course change is completed.

Pressing the **TURN** key followed by either the red or green **ARROW** key will initiate a special turn (Emergency turn, Continuous turn, or U-turn; selected in **STANDBY**) in that direction.

The function display will show an 'E', 'C', or 'U' until the turn is completed.

The **ADJUST** key can now be used to change the Rudder, Counter Rudder, Yaw and Turn Rate settings.

NAV



Place the master select switch in this position when the autopilot is being operated with a navigation computer (i.e. GPS, Loran, etc.) which has an NMEA 0183 data format output.

The autopilot operates the same way as in the **PILOT** position, except that it will change its course as directed by the navigation computer to maintain a Zero Track Error.

The autopilot will display **'Fd:ER'** if there is a problem with the data it is receiving such as Low Signal To Noise Ratio, Blink Alarm, or Incorrect Cycle Selection.

The autopilot will display **'nd:Er'** and maintain its last course if it does not receive any data from the navigation computer.

MEMBRANE KEYPAD

ADJUST KEY

Pressing the ADJUST key repeatedly displays first the Rudder setting, then the Counter Rudder, Yaw and finally the Turn Rate setting for either the FAST or SLOW mode.

Press the **ADJUST** key followed by either the up or down **ARROW** key to switch between the FAST and SLOW modes. This will be done automatically if

the speed sensitivity is turned on. Any setting may be changed between '0' and '9' while it is displayed by pressing the up or down **ARROW** key.

DODGE KEYS

Pressing either the red or green DODGE key will dodge the vessel in that direction.

The display will switch to show the vessel's rudder angle. Pressing and holding both DODGE keys will centre the rudder to hold the vessel off course. Release the DODGE key(s) and the vessel will return to its programmed course.

ALARM CLEAR

The autopilot will sound the alarm when an error condition exists.

This condition will also be indicated on the display. The alarm may be cleared by touching the **ALARM CLEAR** key. If the error condition still exists, the alarm will come on again.

RUDDER

Controls the amount of rudder applied for a given amount of course error.

At the maximum setting of '9', 3 degrees of rudder will be applied for each degree of course error. Every two position reduction in the setting cuts the amount of correction applied in half.

COUNTER RUDDER

Controls the amount of rudder applied for a given rate of change of course error.

If the course error is increasing, the counter rudder adds to the rudder correction applied, and if the course error is decreasing, the counter rudder subtracts from the rudder correction applied. At the maximum setting of '9', 10 degrees of rudder will be applied for a 1 degree per second rate of change of course error. Every two position reduction in the setting cuts the amount of

correction applied in half.

YAW

Controls the amount of deviation from the programmed course the autopilot will allow before correcting the vessel's heading.

Increasing the setting will increase the amount of heading deviation allowed. The number shown on the display is the number of degrees of heading deviation allowed, centred on the programmed course (*i.e. a setting of 4 will allow 2 degree's of heading deviation on either side of the programmed course, before any correction is applied*).

TURN RATE

Controls the rate at which the vessel makes a course change, returns to its original course after a dodge, or changes course under Nav Device control.

The turn rate corresponding to each control setting is shown in **Table V** following.

TABLE V:

SETTING	TURN RATE
0	0.5 DEG/SEC
1	1.0 DEG/SEC
2	1.5 DEG/SEC
3	2.0 DEG/SEC
4	2.5 DEG/SEC
5	3.0 DEG/SEC
6	3.5 DEG/SEC
7	4.0 DEG/SEC
8	4.5 DEG/SEC
9	5.0 DEG/SEC

SPECIAL TURNS

When the autopilot is in the **PILOT** mode, pressing the **TURN** key followed by either the red or green **ARROW** key initiates the **PRE-SELECTED** type of special turn.

EMERGENCY TURN



The Emergency Turn is selected by placing the autopilot in the **STANDBY** mode, pressing the **TURN** key, followed by either the red or green **ARROW** key until the display shows 'E.trn'. This turn is sometimes called the 'man overboard turn' or 'Williamson turn'. If the vessel's speed and turn rate are not changed while the turn is in progress, the autopilot will bring the vessel about in such a way that it retraces its own path in the water.



An Emergency Turn to port is initiated by placing the autopilot in the **PILOT** mode and

pressing the **TURN** key followed by the red **ARROW** key. The autopilot will make a 90-degree turn to port. When that turn is complete, the autopilot will automatically make a 270-degree turn to starboard. The function indicator will change to an 'E' until both turns are complete. When the second turn is complete, the vessel should be retracing its own track in the water. Pressing the **TURN** key followed by the green **ARROW** key does the same thing only the first 90 degree turn is to starboard, and the second 270 degree turn is to port. The speed at which the turns are performed is set by the Turn Rate control, and should not be changed during the turn (otherwise the vessel will not end up on its own track).

CONTINUOUS TURN

The Continuous Turn is selected by placing the autopilot in the **STANDBY** mode, pressing the **TURN** key, followed by either the red or green **ARROW** key until the display shows 'C.trn'.



A Continuous Turn to port is initiated by placing the autopilot in the **PILOT** mode and pressing the **TURN** key followed by the red **ARROW** key. The vessel will turn at the rate determined by the Turn Rate control and will continue to turn until either the red or green **ARROW** key is pressed. The function indicator will show a 'C' until the turn is stopped. The vessel will then travel in the direction indicated on the display. Pressing the **TURN** key followed by the green **ARROW** key will start a similar turn to starboard.

U TURN



The U-Turn is selected by placing the autopilot in the **STANDBY** mode, pressing the **TURN** key, followed by either the red or green **ARROW** key until the display shows 'U.trn'. This turn is also just what it sounds like, a 180 degree turn.



A U-Turn to port is initiated by placing the autopilot in the **PILOT** mode and pressing the **TURN** key followed by the red **ARROW** key. The vessel will turn to port at the rate determined by the Turn Rate control. Pressing the **TURN** key followed by the green **ARROW** key will start a similar turn to starboard. Pressing the **TURN** key followed by the same **ARROW** key during the U-turn will increase it to a full 360 degree turn.

OPERATION

For one second the first thing you will see when the autopilot is turned on is the software revision number. **Example: '01.09'**. This will tell you the version of the computer program in your autopilot.

To tell if you have the most current version of the autopilot program, call the factory with the software revision number displayed. If you do not have the latest version, we will be able to tell you how to have your autopilot updated.

STANDBY

The first operating mode is **STANDBY**. In this mode, the display will show you the vessel's actual compass heading. Any rudder angle indicators fitted will now show the vessel's rudder angle.

This feature requires that the autopilot be interfaced to a navigation device, preferably a GPS, or plotter driven by a GPS, that outputs one of the NMEA 0183 RMA, RMC, VBW, VHW or VTG data sentences.

If the compass heading on the digital display does not agree with the vessels actual heading, adjust the heading offset by the amount of the error. *(For example, if the vessels actual compass heading is 265 and the digital display reads 260, the offset should be increased by 5 degrees as described below.)*



To display the current compass offset, press the **ADJUST** key twice

ADJUST KEY FUNCTIONS IN STANDBY:



Press the **ADJUST** key once to adjust the speed sensitivity.

To increase or decrease the offset, press either the up or down **ARROW** key. (An offset of 005 degrees will add 5 degrees to the compass heading and an offset of 355 degrees will subtract 5 degrees from the compass heading.)

The speed sensitivity is turned off when 'SP: 0' is displayed.

The heading offset may need to be as much as 180 degrees, depending on the type and brand of compass connected to the autopilot



The autopilot will switch from SLOW to FAST when any other value is displayed (when the vessel's speed is one knot or more higher than the displayed speed) and from FAST to SLOW (when the vessel's speed is one knot or more lower than the displayed speed).

To display the current minimum or night time brightness level, press the **ADJUST** key three times.

To increase or decrease the minimum brightness level, press either the up or down **ARROW** key.



To display the battery voltage supplied to the autopilot, press the **ADJUST** key four times.



To turn the checksum evaluation of the RMA, RMB and RMC data sentences on or off, press the **ADJUST** key five times.

To turn on the checksum evaluation, press either the up or down **ARROW** keys until 'cm:ON' is displayed.

To turn off the checksum evaluation, press either the up or down **ARROW** key until 'cm:OF' is displayed.

POWER STEER

The second operating mode is **POWER STEER**. In this mode, the display still shows the vessel's actual compass heading, but now the red and green **ARROW** or **DODGE** keys can be used to turn the rudder port or starboard.

The display will switch to show the vessel's rudder angle any time a red or green **ARROW** or **DODGE** key is pressed.

The positive input voltage will appear on the SWITCHED PWR line to power a solenoid operated 4-way-valve, or to engage the clutch mechanism of a drive unit on a mechanical steering system.

You can still use the wheel if you have hydraulic steering.

If you have mechanical steering, the only operating mode where you can use the wheel is **STANDBY**.

See the *NAVIGATION INTERFACE* section of this manual for more information.

To change the type of special turn (Emergency turn, Continuous turn, or U-turn) that will occur when you select a special turn in the **PILOT** operating mode, press the **TURN** key followed by either the red or green **ARROW** key.

To reset all autopilot parameters back to factory original settings, press and hold both the up and down **ARROW** keys for one second.

A dockside set-up **WILL** be performed after a Full Reset. See the *DOCKSIDE SETUP* section of this manual for more information.

The digital rudder angle display can be locked on by pressing the **TURN** key.

To return the vessels compass heading to the display, press the **TURN** key again.

ADJUST KEY FUNCTIONS IN POWER STEER

To adjust the digital rudder angle indicator

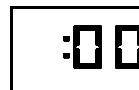

reading so that it reads zero when the rudder is dead ahead, press the **ADJUST** key once. While the reading is flashing, press either the up or down **ARROW** key to adjust the reading.



To set the hard-over to hard-over Rudder Travel, press the **ADJUST** key twice.

This is used to more accurately calibrate the digital rudder angle reading and does not affect how far the rudder moves. Press either the up or down **ARROW** key until the number on the display equals the actual number of degrees of rudder travel.

Rudder Travel can be measured using an analog Rudder Angle Indicator (if one is fitted), or by measuring the stroke of the hydraulic cylinder (Cylinder Stroke) and the distance from the center of the rudder post to the point on the tiller where the cylinder attaches (Tiller Arm Length). Then calculate the hard-over to hard-over Rudder Travel using the following formula.

$$\text{Rudder Travel} = 2 \times \text{Inverse Sine} (\text{Cylinder Stroke} / (2 \times \text{Tiller Arm Length}))$$

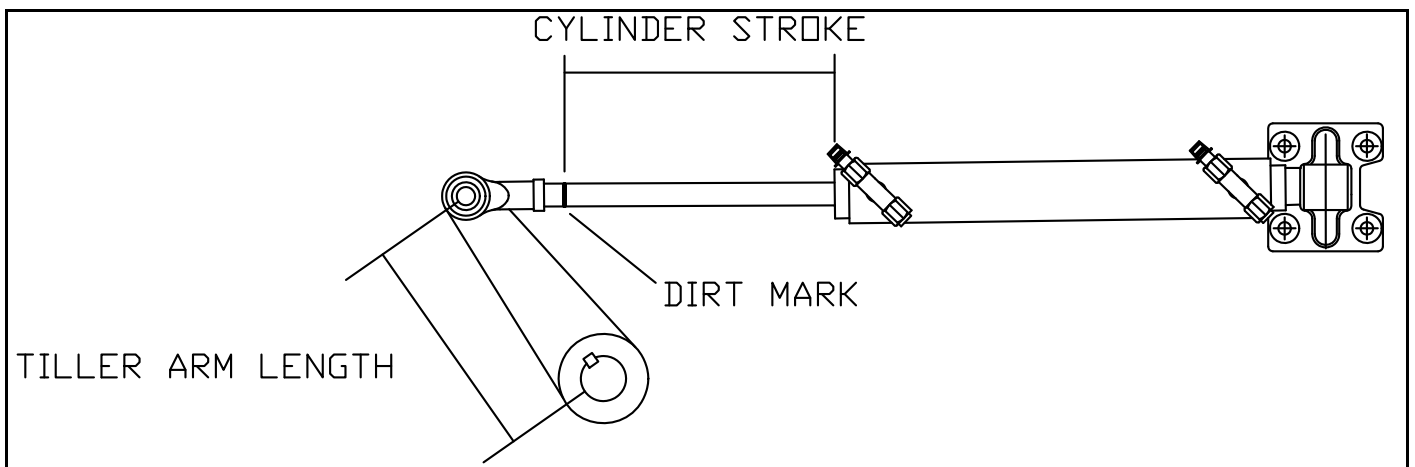

Figure 9- Measure Rudder Travel with Wheel Hard Over

PILOT

The third operating mode is **PILOT**. The autopilot will begin steering the vessel on the last course it was on, just prior to switching to **PILOT**, when you turn the master select switch to this position. The autopilot will use the last rudder angle on the vessel as the first approximation of dead ahead rudder.

*This means that if you are towing a net and require 15 degrees of port rudder to make the vessel steer straight, the autopilot will hold that rudder angle when you turn to **PILOT**.*

If the rudder angle is not correct, the automatic trim function of the autopilot will find the correct dead-ahead rudder angle in approximately one minute.

TO CHANGE THE VESSEL'S COURSE BY ONE DEGREE, press and release the red or green **ARROW** key.

TO MAKE LARGER COURSE CHANGES, press and hold the red or green **ARROW** key, and the display will move at 10 degrees per second until you release the key. The autopilot will bring the vessel around to the new course at the rate set by the Turn Rate control (see 5).

The Function Indicator will show a 'c' until the course change is complete.

Press the **TURN** key followed by either the red or green **ARROW** key and the vessel will make an Emergency turn, Continuous turn, or U-turn (selected in **STANDBY**) in that direction at the programmed rate of turn.

The Function Indicator will show a 'E', 'C' or 'U' until the turn is complete.

If a Navigation Device which transmits any of the **RMA**, **RMC**, **VBW**, **VHW**, or **VTG** sentences is connected to the autopilot, you may choose automatic switching between the FAST and SLOW modes when in Pilot or Nav This works best if the Navigation Device is a GPS or a plotter which is driven by a GPS.

THE SPEED SENSITIVITY IS TURNED ON by rotating the master select switch to the **STANDBY** position and pressing the **ADJUST** key once. The display will change to show '**SP: 0**'.

Press the up **ARROW** key until the speed at which you would like the autopilot to switch from SLOW to FAST is displayed. When the vessel's speed is one knot or more higher than this speed, the autopilot will switch from SLOW to FAST. When the vessel's speed is one knot or more lower than this speed, the autopilot will switch from FAST to SLOW.

THE SPEED SENSITIVITY IS TURNED OFF by either manually switching the autopilot from SLOW to FAST, from FAST to SLOW, or by rotating the master select switch to **STANDBY** and pressing the **ADJUST** key once. The display will change to show '**SP: x**'. Press the down **ARROW** key until the display shows '**SP: 0**'.

If the autopilot fails to receive any speed information from the navigation device, it will alarm and display '**NO:SP**' once every twenty seconds.

The **ADJUST** key can now be used to adjust the Rudder, Counter Rudder, Yaw or Turn Rate settings for either the FAST or SLOW mode.

If the vessel is travelling at high speed, press the **ADJUST** key once followed by either the up or down **ARROW** key until the display reads 'FAST'. *This will occur automatically if the speed sensitivity is turned on.*

TO INCREASE OR DECREASE THE RUDDER SETTING, press the **ADJUST** key until the display reads 'rud' followed by either the up or down **ARROW** key.

TO INCREASE OR DECREASE THE COUNTER RUDDER SETTING, press the **ADJUST** key until the display reads 'Ctr' followed by either the up or down **ARROW** key.

TO INCREASE OR DECREASE THE YAW SETTING, press the **ADJUST** key until the display reads 'YAW' followed by either the up or down **ARROW** key.

TO INCREASE OR DECREASE THE TURN RATE SETTING, press the **ADJUST** key until the display reads 'trn' followed by the up or down **ARROW** key.

The factory settings for Rudder, Counter Rudder, Yaw and Turn Rate are 3, 3, 1 and 6 respectively.

TO SELECT THE SLOW MODE, (if the vessel is travelling at slow speed), press the ADJUST key once followed by either the up or down ARROW key until the display reads 'SLOW'. *This will occur automatically if the speed sensitivity is turned on.*

The Rudder, Counter Rudder, Yaw and Turn Rate settings for the slow mode are adjusted the same way as described above.

The factory settings for Rudder, Counter Rudder, Yaw and Turn Rate are 5, 5, 1 and 6 respectively.

When in doubt about how to determine the correct Rudder and Counter Rudder settings for either the FAST or SLOW modes, try the factory settings shown above.

If you make a large turn, and you see that the vessel overshoots the new course more than once, try either increasing the amount of Counter Rudder by one setting, or reducing the amount of Rudder by one setting. If this does not solve the problem try it again.

If the vessel seems to stop turning before you get to the new course, and then slowly come up to it, try either decreasing the amount of Counter Rudder or increasing the amount of Rudder. *Refer to 0 for a graphic representation of Rudder and Counter Rudder adjustments.*

If nothing seems to make the vessel steer properly, or it steers properly on some headings but not on others, particularly north or south, it is almost always a problem with the compass.

If the autopilot is using a Magnetic Compass, problems could be caused by the compass not having been swung by a qualified compass adjuster; the card may be sticking because of a worn pivot; or the compass may not have been swung properly the first time.

On new steel vessels in particular, the magnetism of the hull can change dramatically over time, and it is not uncommon to require the compass to be swung twice in the first year. Also there is a common misconception that aluminum vessels do not require the compass to be swung because aluminum is non-magnetic. It is, but the welds where the aluminum plates are joined become magnetic because of the amount of energy injected there. For this reason, having the compass properly swung is just as important on an aluminum vessel as on a steel vessel.

If the autopilot is using a fluxgate compass, problems could be caused by the compass being mounted too far from the vessel's center of pitch and roll. The sensor's gimbal may be sticking; or the vessel has such strong magnetism that a compass adjuster is required to manually swing the compass.

The **DODGE** keys may be used to avoid logs or other obstacles in the water ahead. Pressing one **DODGE** key will cause the vessel to make a panic turn in that direction. Pressing both **DODGE** keys when the vessel has turned far enough to miss the obstacle, will make the autopilot bring and hold the rudder to dead ahead.

Release the **DODGE** keys to return the vessel to the original course at the programmed turn rate when the vessel is clear of the obstacle. The Function Indicator will show a 'd' until the dodge is complete.

NAV

The next operating mode is **NAV**. If you have a GPS, Loran or other navigation computer interfaced to the autopilot, program in a waypoint, tell the computer to begin navigating towards the waypoint from the vessel's present position, and turn the autopilot master select switch to **NAV**.

IF YOUR INTERFACE IS USING NMEA 0183 DATA FORMAT, (to see which type of data the autopilot is using to navigate, press the **TURN** key), the first thing that should happen is that the course display on the autopilot will begin to change towards the Heading to the Waypoint as indicated by the Nav Device.

The autopilot will then further alter its course to keep the Cross Track Error as indicated by the Nav Device to a minimum. If you are in any doubt as to whether things are working correctly, **WATCH THE CROSS TRACK ERROR**.

*To change the cross track error response press **TURN** key followed by the green **ARROW** key.*

If it is being maintained at a low value (i.e. less than 0.02 nautical miles), everything is working.

If the vessel is wandering back and forth, but there are no alarms on the autopilot or Nav Device, the most common cause, (particularly with Loran), is poor signal quality. This may be attributed to either:

- poor or no grounding of the Loran,
- noisy alternators on the vessel, or,
- poor antenna location.

Refer to the Nav Device manual for signal quality displays and ideas on making improvements. If the Nav Device is set for automatic waypoint sequencing, the heading to steer will change when the next waypoint is selected. The autopilot will then turn the vessel to the new

course.

HINTS

If the heading to steer can be in degrees magnetic or degrees true, select degrees magnetic and be sure the variation is entered correctly. Course changes during automatic waypoint sequencing will be smoother if the arrival circle is set to a small value such as 0.05 nautical miles. This usually will let the autopilot bring the vessel directly onto the next track when the course change is completed.

IF YOUR INTERFACE ONLY OUTPUTS NMEA 0180 or 0182 FORMAT, consult with the factory service personnel to obtain special software. The 1001 autopilot software only supports NMEA 0183 format.

You can still use the **DODGE** keys to avoid obstacles in the water. The only difference is that after you release the **DODGE** keys, the vessel will return to its original track, rather than its original course, unless you reset the point of origin of the track on the Nav Device.

To prevent the autopilot from making a course change at a bad time, press and hold both **DODGE** keys to lock the rudder at dead ahead. (i.e. if you see an obstacle in the water that the vessel will avoid if it **DOESN'T** make any course changes)

REMOTE CONTROLS

To use the remote control, leave the autopilot in the **PILOT** mode when you go up to the flying bridge. This will leave the vessel under control. At the flying bridge, press both pushbuttons on the remote control and hold them down for one second until you see the command point move to the **REM** position.

The remote control is similar to the main control panel of the autopilot. The remote has a **DODGE/TURN** toggle switch instead of separate pushbuttons for these functions.

For a panic turn, hold the toggle switch in the **DODGE** position and press a pushbutton while in **PILOT** or **NAV**.

To lock the rudder at dead ahead, hold the toggle switch in the **DODGE** position without pressing either pushbutton. Release the toggle switch to return to the original course.

To initiate a special turn while in **PILOT**, push the toggle switch to the **TURN** position and release it. Then press either pushbutton to initiate a U-Turn, emergency turn, or continuous turn.

To change the type of turn, place the master select switch on the remote in the **STANDBY** position. Push the toggle switch to the **TURN** position and release it. Select the type of turn desired by pressing and releasing either the red or green pushbutton.

TO RECALL THE PILOT'S LAST PROGRAMMED COURSE, hold the toggle switch in the **DODGE** position while rotating the master select switch from **POWER STEER** to **PILOT**.

If you have mechanical steering, you can disengage the clutch on the drive unit and return to hand steering by selecting the **STANDBY** mode.

When you want to go back to the main control unit, leave the remote in the **PILOT** mode so the vessel is under control. Walk back to the wheelhouse and press both the red and green **ARROW** keys. Hold them down for one second until the command point moves back to the **MASTER** position.

This page is meant to be blank.

REMOTE CONTROLS

COMNAV 101 REMOTE CONTROL

This remote control plugs into the remote receptacle on the rear of the autopilot. Control is taken at the remote by pressing both its pushbuttons for one second. The command point on all LCD displays will move to the **REM.1** position.

A display, master select switch, pushbuttons, and a **DODGE/TURN** toggle switch are also included. Its operation is identical to the operation of the autopilot except for the toggle switch. All the points on the display have the same meanings as on the autopilot display.

The Rudder Follower Failed point is labelled REM.2 on the 101 Remote Control.

Place the master select switch in the **STANDBY** position. To display the currently selected type of special turn, pull the toggle switch to the **TURN** position and release it

To change the currently selected type of special turn, press either the red or green pushbutton.

Place the master select switch in the **POWER STEER** position. To move the rudder port or starboard, the red and green pushbuttons can be used.

The vessel's rudder angle will be displayed while the pushbutton is pressed.

To recall the vessel's last course, hold the toggle switch in the **DODGE** position and then rotate the master select switch from **POWER STEER** to **PILOT**.

Place the master select switch in the

PILOT position. The autopilot is now steering the vessel on its current heading.

or

If the toggle switch was held in the **DODGE** position while the master select switch was rotated to **PILOT**, the autopilot will steer the vessel back to its last course

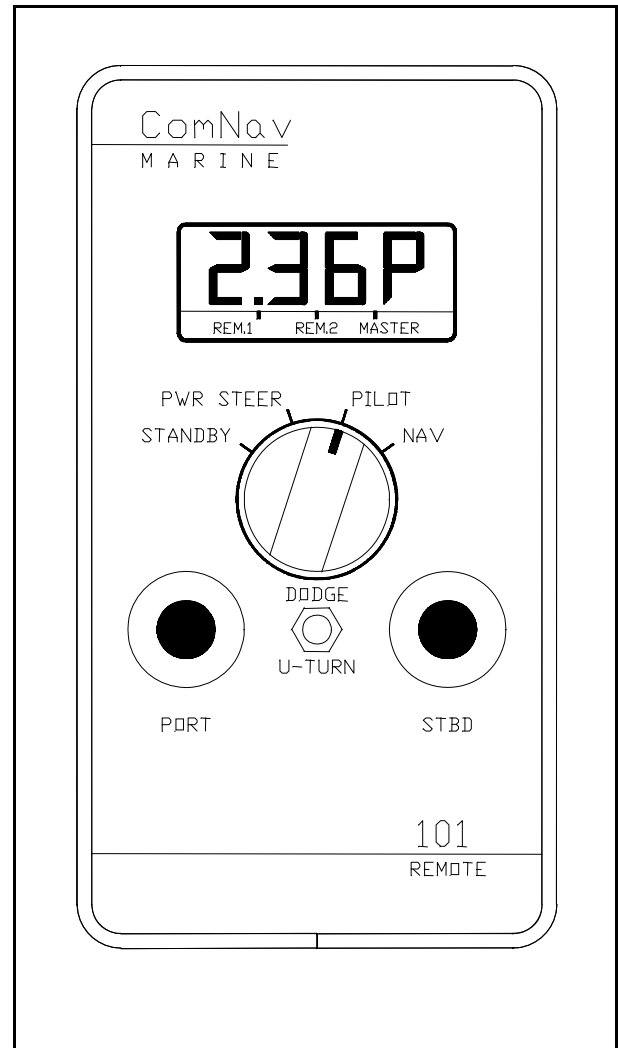

Figure 10- 101 Remote Control

To change the vessel's course by one degree, press and release either the red or green pushbutton.

To change the vessel's course by 10 degrees per second, press and hold either the red or green pushbutton. The vessel will turn to the new heading at the current Turn Rate setting. The vessel can be dodged off course by holding the toggle switch in the **DODGE** position and pressing one of the pushbuttons. The vessel's rudder angle will be displayed.

The rudder can be returned to the Dead Ahead position, holding the vessel off course, by holding the toggle switch in the **DODGE** position without pressing either pushbutton. Release the toggle switch and the vessel will return to the programmed course at the current Turn Rate setting.

The currently selected type of special turn can be started by pulling the toggle switch to the **TURN** position, releasing it and then pressing either the port or starboard pushbutton. The direction of the special turn is determined by which pushbutton is used.

To interface the autopilot with a navigation device, place the master select switch in the **NAV** position.

To display the incoming data type and cross track error sense, pull the toggle switch to the **TURN** position and release it.

To select either Normal or Reversed response to cross track error, press the green pushbutton.

The dodge function works as described earlier, except that the vessel will return to the track to the waypoint rather than the programmed course after the dodge is released.

The back of the remote provides two key-hole slots which can be used to either temporarily deposit or permanently mount it on any suitable location.

TO MOUNT THE REMOTE PERMANENTLY:

Drill two holes for the mounting screws 3.5 in (9.0 cm) apart.

Drop the screws' heads into the keyhole slots and then into the two holes drilled. Fasten the screws with washers and nuts from the back of the mounting surface.

TO MAKE THE REMOTE REMOVABLE FROM IT'S MOUNT.

Provide two #10 pan head stainless steel screws (M5 cylinder head).

Place these 3 inches (7.6 cm) apart in a suitable location, with a gap of 0.1 inches (2.5 mm) between the underside of the screws' heads and the mounting surface. Drop the remote over the screws' heads and pull it down to mount it. Lift it up to remove the remote for hand-held operation.

SEE TABLE VI FOR HOOKUP SPECIFICATIONS.

During the first year, check that the glands are hand-tight every six months and yearly thereafter.

Table VI - 101 REMOTE Cable Connections

Wire Colour	Terminal Number	Plug Pin Number
Shield	1	11
Pink	2	3
White	3	10
Brown	4	2
Violet	5	5
Grey	6	12
Green	7	9
Red	8	8
Yellow	9	7
Black	10	6
Blue	11	4

COMNAV 201 REMOTE CONTROL

This remote control plugs into the remote receptacle on the rear of the autopilot.

Control is taken at the remote by pressing both its pushbuttons for one second. The decimal point on the 1001 Control Head display will move to the **REMOTE** position. The **Standby** mode is a safety feature that allows the remote station to de-activate the autopilot output to the steering drive unit. When the switch is in the **TILLER** position, the vessel's rudder will be turned to the same angle as indicated by the control knob.

To lock the vessel onto a heading under autopilot control, point the vessel onto a desired heading, and then place the switch in the **PILOT** position. The pushbuttons can be used to alter the vessel's heading in one-degree steps, or by 10 degrees per second after holding the pushbutton for half a second.

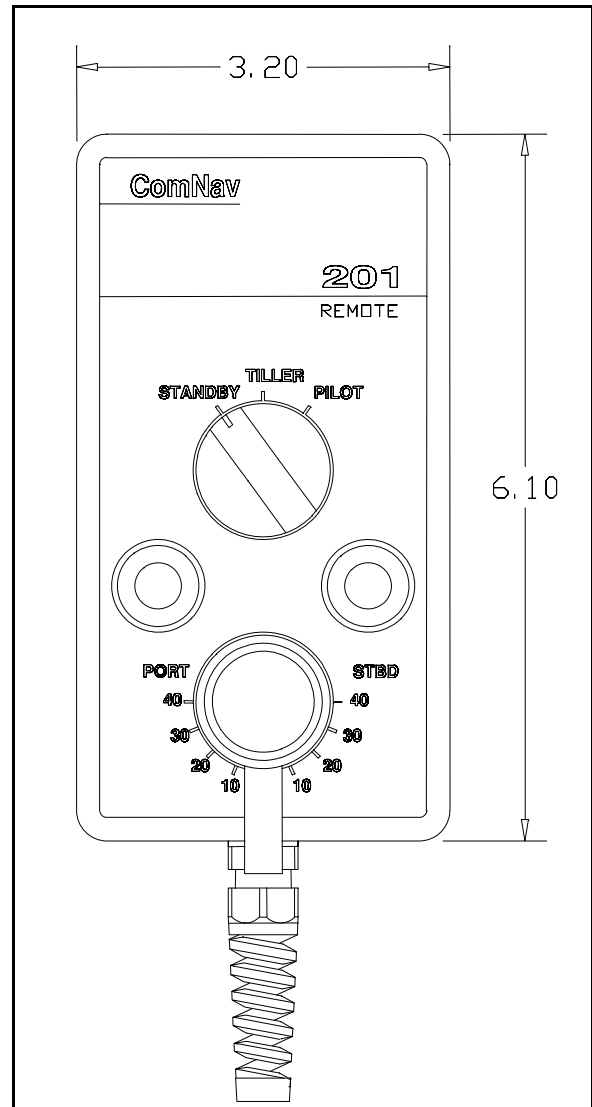

Figure 11- 201 Remote Control

COMNAV 211 REMOTE CONTROL

This remote control plugs into the remote receptacle on the rear of the autopilot.

Control is taken at the remote by pressing both its pushbuttons for one second. The decimal point on the 1001 Control Head display will move to the **REMOTE** position and the decimal point on the 211 Remote display will move to **REM.1**.

The **Standby** mode is a safety feature that allows the remote station to deactivate the autopilot output to the steering drive unit. When the switch is in the **TILLER** position, the vessel's rudder will be turned to the same angle as indicated by the control knob.

To lock the vessel onto a heading under autopilot control, point the vessel onto a desired heading, and then place the switch in the **PILOT** position. The pushbuttons can be used to alter the vessel's heading in one-degree steps, or by 10 degrees per second after holding the pushbutton for half a second.

The **DODGE/U-TURN** toggle switch operates identically to the COMNAV 101 remote.

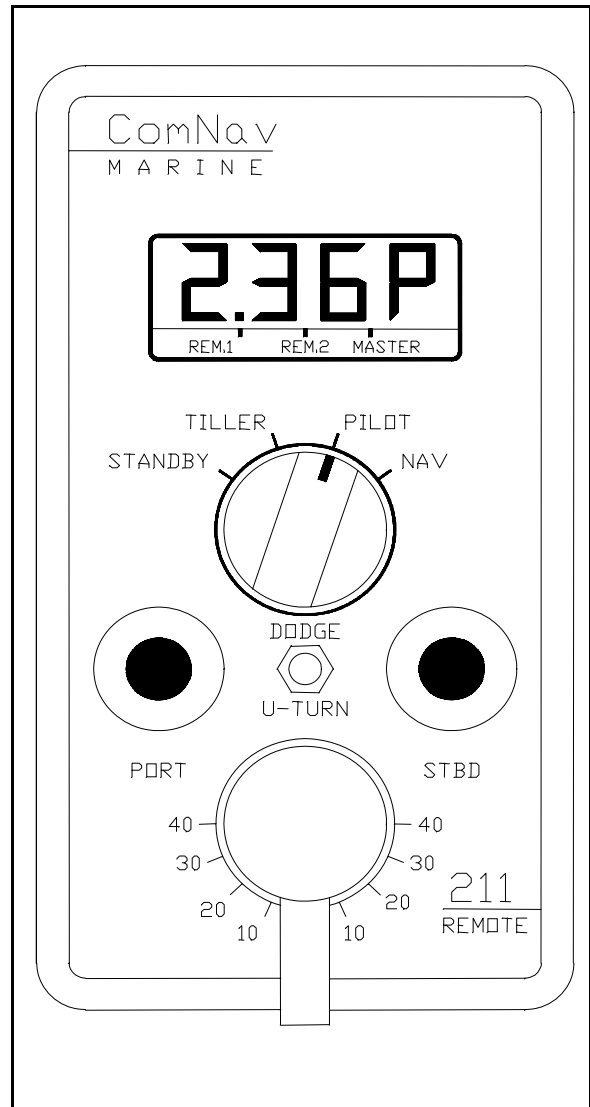

Figure 12 - 211 Remote Control

ERROR CHECKING

THE AUTOPILOT WILL DISPLAY AN ERROR MESSAGE AND SOUND THE ALARM WHEN ANY OF THE FOLLOWING CONDITIONS EXIST:



**CHECKSUM
ERROR**

The checksum in one of the RMA, RMB or RMC data sentences is set incorrectly or there is a transmission problem between the navigation device and the autopilot.

If you choose to continue using the interface, the checksum evaluation can be turned off by rotating the master select switch to STANDBY and pressing the **ADJUST** key until the display shows 'cn:ON'. Press either the up or down **ARROW** key until the display shows 'cn:OF'.



COURSE ERROR

The vessel has fallen more than 20 degrees off course and has remained off course for more than 30 seconds.

This indicates a possible failure of the rudder follower, or more likely, the power steering system. Check for an inoperative motor drive, blown breaker to the motor, jammed four-way-valves, etc..



**FAULTY
COMPASS ERROR**

There is a problem with the circuitry inside the autopilot associated with the compass interface.

The autopilot is operable in non-autopilot modes only (i.e. STANDBY or POWER STEER).



**FAULTY DATA
FROM NAV
DEVICE ERROR**

One or more of the alarm flags in the data sentence from the Nav Device are set.

The autopilot will continue to use the data, but will sound the alarm and display this error message after every data sentence received until the error flags are cleared. Extreme caution should be used if the autopilot is left in the **NAV** mode.

Check the front display of the Nav device for an alarm message. If the alarm continues for more than 30 seconds, disengage the autopilot.



FRONT PANEL
ERROR

One or more of the keys on the front panel are stuck in the closed position or a remote may have a faulty pushbutton.

The autopilot or remote can be used by pressing ALARM CLEAR, however, some functions may not work properly.



FULL RESET

If the test of the permanent memory indicated that one or more of the bytes of data stored were not correct, a number of controls are reset to pre-determined values.

Return the FAST and SLOW Rudder, Counter Rudder, Yaw and Turn Rate settings to their previous values. Autopilot will automatically start Dockside Set-up program after Full Reset.



GHOST RUDDER
ON

If the rudder follower is defective the autopilot will display this message each time it is switched between POWER STEER and PILOT.

This will remind you that it is using the Ghost Rudder program. The autopilot will not work as well with the Ghost Rudder as it will with the Rudder Follower so the Rudder Follower should be repaired or replaced as soon as possible.



HIGH POWER
ERROR

The voltage into the autopilot has risen above 35 VDC and the autopilot may get damaged.

Open the breaker which supplies power to the autopilot, determine the cause of the high voltage and rectify it. Check the voltage regulator as it is the most likely problem.



MOTOR LOAD
ERROR

Autopilot is being used with motor drive which feeds its operating current & temperature back to the autopilot (i.e. CT2 Drive Box), and levels exceed safe margins for more than 4 seconds. LOAD shows while in the PILOT or NAV modes. HOt shows while in the STANDBY or POWER STEER modes.

Check for a jammed rudder, or similar problem which would cause this to happen.

- or -



DRIVE BOX
OVERHEATED



The autopilot has detected that its input voltage has dropped under 10 VDC.

Check for proper alternator operation, batteries low on water, or some other condition that has caused the input voltage to drop.

**LOW POWER
ERROR**



The computer is not receiving any data from the compass.

Check that the compass is plugged into the autopilot. The autopilot is operable in non-autopilot modes only (i.e. **STANDBY** or **POWER STEER**). Check that the autopilot is programmed for the correct type of compass (see DOCKSIDE SETUP for information).

**NO COMPASS DATA
ERROR**



The autopilot is not receiving any recognizable data from the Nav Device.

This could be because 1) the Nav Device is not programmed correctly; 2) the Nav Device is not putting out any data; 3) there is a problem with the cabling between the Nav Device and the autopilot (i.e. broken or reversed wires); or 4) there is a fault with the autopilot interface circuitry. Some Nav Devices will not put out a data sentence for the autopilot until a waypoint has been entered, and navigation towards it started.

**NO DATA FROM
NAV DEVICE ERROR**



The autopilot is in the PILOT or NAV mode, the speed sensitive selection of the FAST or SLOW operating modes is turned on and the autopilot is not receiving any speed information from the navigation device.

Check that the device transmits one of the RMA, RMC, VBW, VHW or VTG data sentences and that it is turned on. Check the cable which connects the navigation device to the autopilot distribution box, especially if you get a No Data error when the autopilot is in the NAV mode.

NO SPEED ERROR



The memory chip, which contains the autopilot program, tested faulty.

The autopilot is not operable.

**PROM MEMORY
ERROR**



RAM MEMORY
ERROR

The portion of RAM memory used for temporary data storage tested faulty.

The autopilot is not operable.



RUDDER
FOLLOWER ERROR

The autopilot has detected a problem with the rudder follower.

Check for broken, disconnected or shorted wires, or a defective rudder follower. The autopilot will switch to using the Ghost Rudder program to control the rudder when the master select switch is in the **PILOT** or **NAV** position. The digital and analog rudder angle displays will not function in any mode. The **RF:ER** error message will remain visible and the audible alarm will stay on until cleared. Even though the alarm is cleared, the Rudder Follower "Failed Point" on the display will remain visible.



RUDDER ERROR

The autopilot has failed to detect any movement by the rudder in response to a command to move.

This error will only occur if the master select switch is in the **PILOT** or **NAV** position.

Place the master select switch in the **POWER STEER** position and measure how long it takes after pressing the red or green **ARROW** key until the digital rudder angle reading begins to change, particularly when the last rudder movement was in the other direction.

If it takes longer than one second for the rudder to begin to move, check for something which could cause a delay in the response of the steering system such as air in the hydraulic steering or slack or worn parts in the mechanical steering system.

Check for too low a setting of the Minimum Speed Potentiometer in the **CT1** Motor Drive Box (if one is used by the autopilot).

If the digital rudder angle display does not change, but the rudder is definitely moving, check for a broken rudder follower linkage, or a defective rudder follower.

If any of these alarm conditions occur, and cannot be easily rectified, return the autopilot to an authorized service centre for servicing.

PROBLEM SOLVING

Several different problems and possible solutions are outlined below. If the recommended solution does not solve the problem, return the autopilot to an authorized service centre.

THE AUTOPILOT DOES NOT TURN ON.

Check for power reaching the distribution box.

Check the main fuse or breaker panel.

Check that the main interconnect cable is properly plugged into the rear of the autopilot.

Check the fuse in the autopilot distribution box. If it is blown, replace it with a 5 X 20 mm 3.15 amp fuse. One spare fuse of this value has been taped to the underside of the autopilot distribution box lid. **Make sure the power leads are not reversed before using the spare fuse.**

THE AUTOPILOT DOES NOT TURN ON, BUT THE ALARM SOUNDS CONTINUOUSLY.

Check for a short circuit between +5V and ground.

Disconnect all leads in the distribution box except PILOT PWR (+) and PILOT PWR (-). If this solves the problem, then reconnect one set of leads at a time until the problem re-occurs. The problem lies with the cabling to that external device, or the external device itself (i.e. a drive box, the rudder follower, a remote heading display, etc.).

If the problem does not disappear after disconnecting all the leads, then there is something wrong with the autopilot. Return it to the factory or an authorized service centre for servicing.

THE AUTOPILOT TURNS ON, BUT DOES NOT TURN THE RUDDER.

Press the red and green **ARROW** key when the autopilot is in the **POWER STEER** mode. The red and green PORT and STBD LED's should come on in the distribution box. If all is correct the problem is not in the autopilot.

Check for a fault in the power steering system (i.e. blown breaker or fuse in electric system, broken drive belt or jammed four way valve, etc.).

Check for a possible short in the output cable to the rudder drive. (continued next page)

THE AUTOPILOT TURNS ON, BUT DOES NOT TURN THE RUDDER. (continued from page 56)

Check for full output voltage on the SWITCHED PWR line with autopilot in the **POWER STEER** mode. The yellow SWI POWER LED in the distribution box should come on when the master select switch on the autopilot is in the **POWER STEER** or higher mode.

Check that the voltage on the PORT OUT and STBD OUT lines drop to less than 1.5 volts when their respective keys are pressed.

Check the rudder drive for correct operation. For a 12 volt 4-way valve, the common line from the solenoids must be connected to UNSWITCH.PWR (terminal 3 in the distribution box), rather than to SWITCHED.PWR.

THE RUDDER TURNS HARD OVER TO ONE SIDE.

Check the rudder follower for correct operation.

Check the rudder drive for correct operation (i.e. sticking relays, sticking solenoid valves, etc.).

If the rudder appears to move normally with the autopilot in **POWER STEER**, but goes hard over with the autopilot in **PILOT**, recheck the rudder follower and rudder drive connections in the distribution box for correct hook-up. Perform the dockside set-up again.

THE AUTOPILOT TURNS ON, BUT DOES NOT OPERATE PROPERLY.

Turn the master select switch to **OFF** and then to **STANDBY** to restart the computer program.

Check the voltage in the distribution box for a minimum of 10.0 VDC between PILOT PWR and PILOT COM.

Check for problems in the cables leading to the optional remote controls by unplugging them from the rear of the autopilot.

THE DISPLAYED COMPASS HEADING DOES NOT FOLLOW THE ACTUAL COMPASS HEADING PROPERLY.

Check for any compensating magnets, particularly heeling magnets that are placed too close to the fluxgate sensor.

Check for any magnetic material such as tools, tin cans, etc., near the compass, or directly underneath it, perhaps in a drawer or cabinet.

THE AUTOPILOT STEERS NORMALLY ON SOME COURSES, BUT NOT ON OTHERS, PARTICULARLY NORTH OR SOUTH.

The problem most likely lies with poor compass adjustment. Contact a compass adjuster to have the compass compensated for deviation, including that caused by heeling error. *Proper compass adjustment is particularly important on steel-hulled vessels. Do not attempt to move any compensating magnets yourself, as this may make the compass dangerously inaccurate, particularly if it is used as a steering compass.*

THE AUTOPILOT STEERS POORLY ON ALL COURSES.

Watch the card on the autopilot compass to make sure that it follows the vessel's movements properly. If the card seems to turn with the vessel for a few degrees, and then come free, either the pivot or jewel in the compass may be defective.

THE REMOTE CONTROL DOES NOT WORK AT ALL.

Check the 'Remote in Command' point to see if the remote is in control.

Check very carefully that the wires are inserted into the terminal block in the remote control in the correct order, and not in reversed order.

THE RUDDER DOES NOT ALWAYS MOVE EVEN THOUGH THE PORT OR STARBOARD OUTPUT LED IS LIT ON THE AUTOPILOT FRONT PANEL AND THE AUTOPILOT IS USING A CT1 DRIVE BOX.

Recheck all the connections between the autopilot and the drive box, making sure that none are interchanged.

Remove the cover of the CT1 Motor Drive Box and check the setting of the minimum speed potentiometer for too low a minimum speed.

THE RUDDER LIMITS DO NOT SEEM TO BE CORRECTLY SET AND THE AUTOPILOT IS USING A CT2 DRIVE BOX.

Make sure that there is **NO** connection between the COM terminal in the Drive Box and any terminal in the autopilot Distribution Box.



CE COMPLIANCE

This product has been tested and is in compliance with the Electro-Magnetic Compatibility (EMC) standards of the European Community and bears the CE label. It has been tested according to the applicable sections outlined under;
Technical standard #IEC945/EN60945
Marine Navigational Equipment
General Requirements

Applicable sections for methods of testing and required test results are;

- Section 4.5.4: Radiated interference
- Section 4.5.4: Immunity to electro-Magnetic Environment
- Annex A, Section A.3: Immunity to conducted audio frequencies
- Annex A, Section A.4: Immunity to earth lead coupling
- Annex A, Section A.5: Immunity to conducted radio frequencies
- Annex A, Section A.6: Immunity to radiated interference

Test results and a declaration of conformity are on file at the ComNav plant;

ComNav Marine Ltd
#15 - 13511 Crestwood Place
Richmond, BC, V6V 2G1, Canada

LIMITED WARRANTY AGREEMENT

Congratulations, you have purchased sophisticated and sensitive marine navigation equipment (the "Equipment") manufactured by ComNav Marine Ltd of #15 - 13511 Crestwood Place, Richmond, British Columbia, Canada, V6V 2G1 ("ComNav").

LIMITED ONE YEAR WARRANTY. ComNav warrants to the Purchaser, provided that the recommended installation and maintenance procedures set forth in the manual that has been provided with the Equipment (the "Manual") have been followed, and subject always to the other provisions of this Agreement, that the Equipment is free from defects in workmanship and materials under normal use and service and will perform substantially in accordance with the specifications set forth in the Manual for a period of one (1) year from the date of purchase of the Equipment by the Purchaser.

EXTENDED THREE YEAR LIMITED WARRANTY. If;

- (a) the Equipment is installed:
 - (i) by an authorized ComNav Dealer; or
 - (ii) by someone other than an authorized ComNav Dealer, and such installation has been inspected by an Authorized ComNav Dealer; and
- (b) the Limited Warranty Registration Card has been returned to ComNav within 14 days of the date of purchase of the Equipment by the Purchaser with Part I thereof having been completed by the Purchaser, and with the Extended Limited Warranty Card having been completed and signed by an authorized ComNav Dealer and returned to ComNav within 14 days of that inspection;

ComNav warrants to the Purchaser that the Equipment is free from defects in workmanship and materials under normal use and service and will perform substantially in accordance with the specifications set forth in the Manual for a period of three (3) years from the date of purchase of the Equipment, subject always to the other provisions of this Agreement.

NO OTHER WARRANTIES. TO THE MAXIMUM EXTENT PERMITTED BY APPLICABLE LAW, COMNAV DISCLAIMS ALL OTHER WARRANTIES AND CONDITIONS, EITHER EXPRESS OR IMPLIED, STATUTORY OR OTHERWISE WITH RESPECT TO THE EQUIPMENT, INCLUDING BUT NOT LIMITED TO IMPLIED WARRANTIES OR CONDITIONS OF MERCHANTABILITY AND FITNESS FOR THE ORDINARY PURPOSES FOR WHICH THE EQUIPMENT IS USED OR FITNESS FOR A PARTICULAR PURPOSE AND ANY OTHER OBLIGATIONS ON THE PART OF COMNAV, ITS EMPLOYEES, SUPPLIERS, AGENTS, OR REPRESENTATIVES.

NO LIABILITY FOR CONSEQUENTIAL DAMAGES. TO THE MAXIMUM EXTENT PERMITTED BY APPLICABLE LAW, IN NO EVENT SHALL COMNAV, ITS EMPLOYEES, SUPPLIERS, OR REPRESENTATIVES BE LIABLE FOR ANY DAMAGES WHATSOEVER, INCLUDING WITHOUT LIMITATION DAMAGE FROM COLLISION WITH OTHER VESSELS OR OBJECTS, INJURY TO ANY PERSON OR PERSONS, DAMAGE TO PROPERTY, LOSS OF INCOME OR PROFIT, BUSINESS INTERRUPTION, OR ANY OTHER CONSEQUENTIAL, INCIDENTAL, RESULTING PUNITIVE, OR SPECIAL DAMAGES ARISING OUT OF THE USE OF OR INABILITY TO USE THE EQUIPMENT, INCLUDING THE POSSIBLE FAILURE OR MALFUNCTION OF, OR DEFECTS IN THE EQUIPMENT, OR ANY PART THEREOF, EVEN IF COMNAV HAS BEEN ADVISED OF THE POSSIBILITY OF SUCH DAMAGES. SOME STATE/JURISDICTIONS DO NOT ALLOW THE EXCLUSION OR LIMITATION OF CONSEQUENTIAL OR INCIDENTAL DAMAGES, SO THE ABOVE LIMITATION MAY NOT APPLY TO THE PURCHASER.

REMEDIES NOT TRANSFERABLE. The Purchaser's remedies under this Agreement only apply to the original end-user of the ComNav Equipment, being the Purchaser, and only apply to the original installation of the Equipment. The Purchaser's remedies under this Agreement are not transferable or assignable by the Purchaser to others in whole or in part.

NOTICE OF DEFECT. The Limited Warranty and the Extended Limited Warranty will not apply with respect to any defective Equipment unless written notice of such defect is given to ComNav, by mail to the address for ComNav set forth above, or by facsimile to ComNav at 1-604-207-8008, and is received by ComNav within ten (10) days of the date upon which the defect first became known to the Purchaser. Notices sent by mail will be deemed to be received by ComNav on the seventh (7th) day first following the date of posting in North America and on the tenth (10th) day next following the date of posting anywhere else in the world. Notices sent by facsimile will be deemed to be received by ComNav on the date of transmission with appropriate answerback confirmation.

WARRANTY LIMITATIONS. Reversing Pumps & Motors, Hydraulic Linear Actuators, Watch Alarms & Motor Control Boxes which may comprise part of the Equipment are warranted by ComNav for a period of two (2) years under the Extended Limited Warranty described above. All Remote Controls, Remote Cables, Jog Switches, Analog meters (rudder angle indicators), Rudder Angle Indicator Systems & Accessories, Magnetic Compasses & Accessories, Constant Running Pumps, Engine Driven Pumps, Hydraulic Manifolds & Hydraulic Steering are warranted by ComNav for a period of one (1) year under the Limited Warranty described above.

IMPLIED WARRANTIES. Any implied warranties with respect to the Equipment are limited to one (1) year. Some states/jurisdictions do not allow limitations on how long an implied warranty lasts, so the above limitation may not apply to the Purchaser.

CUSTOMER REMEDIES. ComNav's entire liability and the Purchaser's exclusive remedy against ComNav for the defective Equipment shall be, at ComNav's option, either: (a) repair or replacement of the defective Equipment under the warranties set forth in this Agreement, or, (b) refund of the purchase price of the defective Equipment, all pursuant to and in accordance with the conditions set out below:

1. If the Equipment, or any part thereof, proves to be defective within the relevant warranty period, the Purchaser shall do the following:
 - (a) contact ComNav by phoning 1-604-207-1600 to discuss the nature of the problem and obtain shipping instructions (many times a satisfactory solution can be reached without returning the item); and
 - (b) prepare a detailed written statement of the nature of and circumstances of the defect, to the best of the Purchaser's knowledge, including the date of purchase of the Equipment, the place of purchase, the name and address of the installer, and the Purchaser's name, address and telephone number to be sent, along with proof of purchase, to ComNav;
2. If upon examination by either ComNav or by an Authorized ComNav Dealer, the defect is determined to result from defective workmanship or material and if the defect has occurred within the relevant warranty period set forth above, the Equipment or the defective parts thereof will be repaired or replaced, at ComNav's sole option, without charge, and shall be returned to the Purchaser at ComNav's expense. Return delivery will be by the most economical means. Should the Purchaser require the Equipment to be returned by a faster method, the costs incurred by expedited delivery will be pre-paid by the Purchaser;
3. No refund of the purchase price for the Equipment will be made to the Purchaser unless ComNav is unable to remedy the defect after having a reasonable number of opportunities to do so. Prior to refund of the purchase price, the Purchaser must submit a statement in writing from an Authorized ComNav Dealer that the installation instructions in the Manual have been complied with in full and that the defect remains;
4. Warranty service shall be performed only by ComNav or by an Authorized ComNav Dealer. Any attempt to remedy the defect by anyone else shall render the warranties set forth in this Agreement void;
5. Charges for overtime, stand-by, holiday and per diem will not be paid by ComNav and are specifically excluded from the warranties set forth in this Agreement. ComNav may, under special circumstances, and with ComNav's PRIOR approval, pay ONE TIME travel costs. Any cost of ferry, boat hire, or other special means of transportation must have prior approval from ComNav. ComNav reserves the right to refuse service charges in excess of one hour if the technician has not contacted ComNav's service department for assistance. Travel cost allowance to service certain Equipment with a suggested retail price of below \$2,500.00 (Canadian funds or equivalent) is not authorized. If repairs are necessary, these products must be forwarded to ComNav or an Authorized ComNav Dealer at Purchaser's expenses and will be returned as set out in **CUSTOMER REMEDIES**, Item 2;

6. **There shall be no warranty for defects in, or damages to, the Equipment caused by:**
- (a) faulty installation or hook-up of the Equipment;
 - (b) abuse, misuse or use of the Equipment in violation of the instructions set forth in the Manual;
 - (c) shipping, alterations, incorrect and/or unauthorized service;
 - (d) **accident, exposure of the Equipment to excessive heat, fire, lightning, salt or fresh water spray, or water immersion except for Equipment specifically designed as, and stated in the Manual to be, waterproof. Water damage to the Equipment due to failure to cover unused receptacles is specifically excluded from any warranty set forth in this Agreement;** and
 - (e) improper or inadequate ancillary or connected equipment;
7. This warranty does not cover routine system checkouts, alignment, or calibration unless the service has been authorized in writing by ComNav PRIOR to its commencement; and
8. No Equipment shall be repaired or replaced under warranty if the serial number of that Equipment has been removed, altered or mutilated.

CHOICE OF LAW AND JURISDICTION. This Agreement is governed by the laws of the Province of British Columbia, Canada. If you acquired the Equipment outside of Canada, each of the parties hereto irrevocably attorn to the jurisdiction of the courts of the Province of British Columbia, Canada and further agree to settle any dispute, controversy or claim arising out of or relating to this Limited Warranty, or the breach, termination, or invalidity of it, by arbitration under the rules of the British Columbia International Commercial Arbitration Centre ("BCICAC"). The appointing authority shall be BCICAC [or, if the BCICAC shall cease to exist, the Chief Justice of the Supreme Court of British Columbia]. BCICAC shall administer the case in accordance with BCICAC Rules. There shall be one arbitrator and the place of arbitration shall be Vancouver, British Columbia.

The *United Nations Convention on Contracts for the International Sale of Goods Act*, S.B.C. 1990, c. 20, and any other statutory enactments of the *United Nations Convention on Contracts for the International Sales of Goods* do not apply to this Agreement.

THIS LIMITED WARRANTY GIVES THE PURCHASER SPECIFIC LEGAL RIGHTS. THE PURCHASER MAY ALSO HAVE OTHERS WHICH VARY FROM STATE/JURISDICTION TO STATE/JURISDICTION.

This Agreement is a legal contract between you (the "Purchaser") and ComNav. By retaining the Equipment for more than thirty (30) days and/or installing and/or using the Equipment, the Purchaser agrees to be bound by the terms of this Agreement. If the Purchaser does not agree to be bound by the terms of this Agreement, the Purchaser may return the Equipment in the same condition in which it was received for a full refund (less shipping and handling costs) within thirty (30) days of purchase.

WARNING. The Equipment is an aid to navigation only. It is not intended or designed to replace the person on watch. A qualified person should always be in a position to monitor the vessel's heading, watch for navigational hazards and should be prepared to revert to manual steering immediately if an undesired change of heading occurs, if the heading is not maintained within reasonable limits, or when navigating in a hazardous situation.

**ALWAYS REMEMBER:
WHENEVER UNDER WAY, A QUALIFIED PERSON ON WATCH IS REQUIRED BY LAW.**

MANUAL PUBLISHED BY:

COMNAV MARINE LTD
#15 - 13511 Crestwood Place
Richmond, BC
CANADA V6V 2G1

TELEPHONE: 604-207-1600
FACSIMILE: 604-207-8008
E-MAIL: sales@comnav.com
WEB SITE: www.comnavmarine.com

TOLL FREE IN CANADA OR THE USA;
PHONE: 1-800-428-0212
FAX: 1-800-470-9611

**THE 1001 AUTOPILOT SYSTEM COMPLIES
WITH ALL RELEVANT CE REGULATIONS**

FIRST PRINTING DECEMBER 1990
REVISED December 1998

MANUAL CHANGES

DECEMBER 27, 1996

- 1) PAGE 31 - A STERNER, MORE DETAILED WARNING WAS GIVEN REGARDING RESIDUAL AIR AS WELL LEAKING FITTINGS AND EQUIPMENT.
- 2) PAGE 15 - WARNING ADDED ABOUT ATTAINING A 10 TO 15 SECOND H.O. TIME.

FEBRUARY 12, 1997 - CE CERTIFICATION DETAILS ADDED

MARCH 17, 1997

PAGES 5, 6 & 7 - NEW WARRANTY POLICY

December 14, 1998

Converted to Word. Removed all 1001M information & W/F references

April 28, 1999

Removed all old drawing and replaced with new KVH Gyro Trac drawing.

August 29, 2000

Change ComNav's address.